

# DENISON HYDRAULICS goldcup series closed circuit piston pumps P6, P7, P8S

## service information

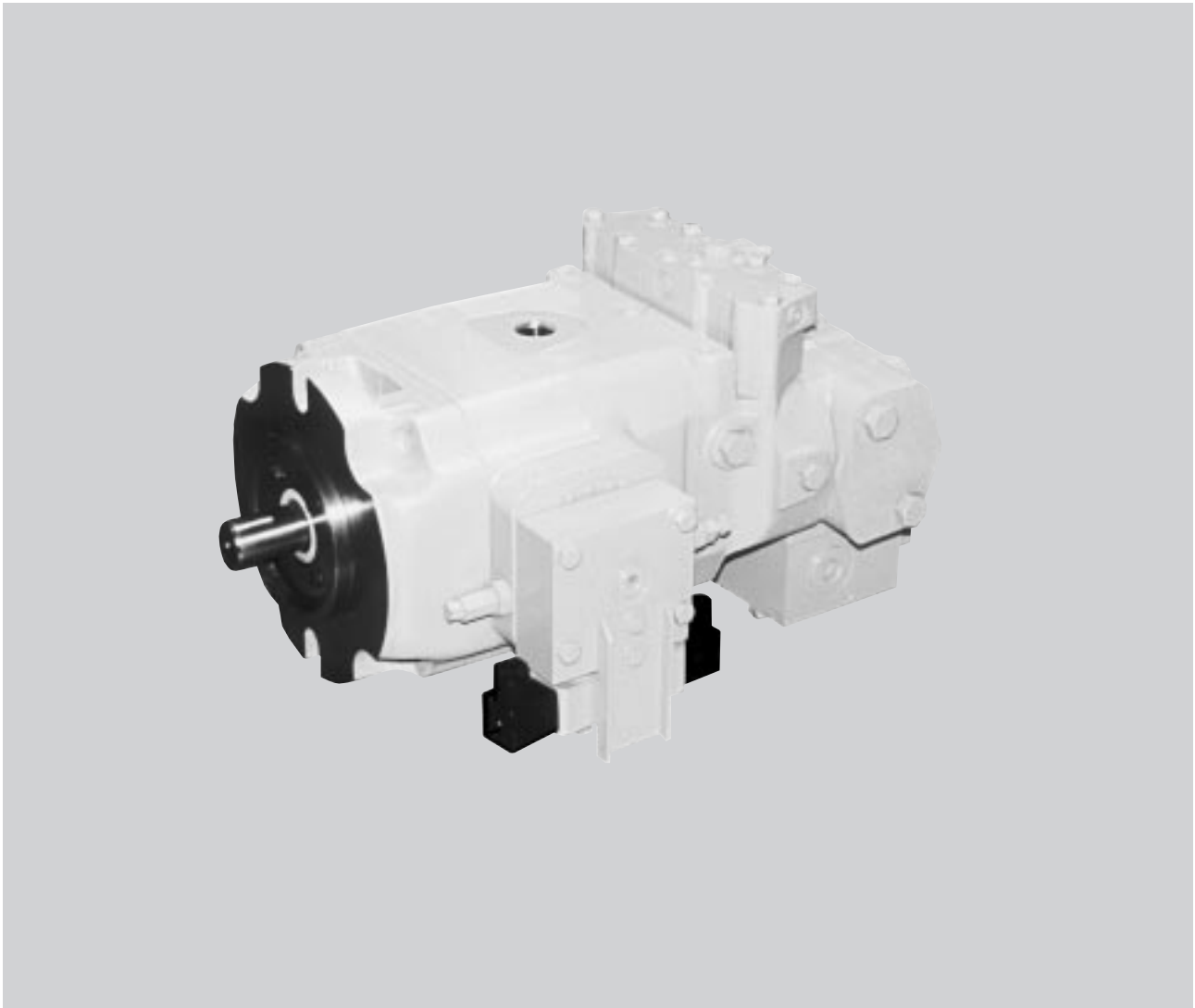

Publ. LT3-00058-2 Replaces S1-AM025-A

Revised 9/02

**DENISON** Hydraulics

E-Mail: [denison@denisonhydraulics.com](mailto:denison@denisonhydraulics.com) Internet: <http://www.denisonhydraulics.com>

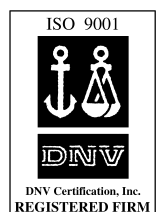

	<b>PAGE</b>
installation	3
typical characteristics	3
fluid connections	4
general	5
description	5
mounting	5
shaft information	5
piping	5
service information	5
recommended fluids	5
viscosity	6
viscosity index	6
temperature	6
alternate fluids	6
maintenance	6
fluid cleanliness for new installation	6
start-up procedure	6
comparison of solid contamination classification system	7
troubleshooting	7
assembly tool drawings, T1, T2, T3, T4, T5	9
disassembly	11
rework of wear parts	12
assembly	13
drive shaft and bearing	13
barrel and auxiliary drive shaft	13
rocker cam	15
pistons and shoes	16
mounting flange, cam & cradle	16
housing	17
housing, end cap, cam and barrel	17
port block	18
mounting port block to housing	18
gerotor and barrel holddown	19
valve block ( <i>before 7-93</i> )	20
valve block ( <i>after 7-93</i> )	22
valve block for special mounting of servo valve ( <i>before 7-93</i> )	26
valve block for special mounting of servo valve ( <i>after 7-93</i> )	29
output controls	32
input controls	32
shaft and seal installation	33
mechanical shaft seal assembly procedure	33
counter-balance servo stem	34
rear drive adapter	34
pilot valve	36
shuttle valve	36
shuttle valve mounting	37
important instructions	38
instructions for replenishing circuit isolation plug	38
hydraulic circuit	40
test procedure	41
general requirements	41
basic pump test	41
(refer to manual S1-AM030 for controls service information)	
ordering code	43
<b>seal kits</b>	
<b>complete</b>	<b>S23-15092</b>
<b>valve block</b>	<b>S23-00135</b>
<b>HI-IQ valve block</b>	<b>S13-04226</b>
<b>shaft seal replacement</b>	<b>S23-44302</b>
<b>shaft seal</b>	<b>623-00006</b>
<b>shuttle valve</b>	<b>S23-15089</b>

**Note: New revisions are shown underlined.  
Pages are marked Revised where changes have been made.**

## INSTALLATION

### TYPICAL CHARACTERISTICS

Specification	Term	P 6	P7	P8
• displacement at max. angle	in. <sup>3</sup> /rev. cm <sup>3</sup> /rev	6.00 (98)	7.25 (119)	8.00 (131)
• pressure ports A & B max. continuous	psi bar	5000 (345)	5000 (345)	3600 (248)
max. intermittent	psi bar	6000 (414)	6000 (414)	4350 (300)
• speed, max. continuous	rpm	3000	3000	1800
• flow, ports A or B @ 1500 RPM (theoretical )	gpm L/min.	38.9 (147)	47.1 (178)	51.9 (196)
• flow, ports A or B @ 1800 RPM (theoretical )	gpm L/min.	46.8 (177)	56.9 (214)	62.3 (236)
• flow, internal replenishing pump @ 1800 RPM (theoretical )	gpm L/min.	6.9 (26.1)	6.9 (26.1)	6.9 (26.1)
• flow, auxiliary pump, external at 1800 RPM (theoretical) (see note)	gpm L/min.	9.3 (35.2)	9.3 (35.2)	9.3 (35.2)
• replenishing pressure	psi bar	200 (14)	200 (14)	200 (14)
• servo pressure	psi bar	335-535 (23-37)	335-535 (23-37)	335-535 (23-37)
• mounting-2 bolt flange	SAE	C	C	C
• shaft-spline keyed	SAE	C	C	C
• fluid connection ports A & B SAE-4 bolt pad for 6000 split flange	in mm	1-1/2 (38.1)	1-1/2 (38.1)	1-1/2 (38.1)
• weight w/rotary servo	lbs. kg.	335 (152)	335 (152)	335 (152)

**Note:** Any SAE-A or B mount pump may be used with the appropriate external drive

The product information, specifications, and descriptions contained in this publication have been compiled for the use and convenience of our customers from information furnished by the manufacturer; and we can not, and do not, accept any responsibility for the accuracy or correctness of any description, calculation, specification, or information contained herein. No such description, calculation, specification, or information regarding the products being sold has been made part of the basis of the bargain, nor has same created or amounted to an express warranty that the products would conform thereto. **We are selling the goods and merchandise illustrated and described on this publication on an "as is" basis, and disclaim any implied warranty, including any warranty of merchantability or warranty of fitness for any particular purpose whatsoever, with respect to the goods and merchandise sold.** All manufacturer warranties shall be passed on to our customers, but we shall not be responsible for special, indirect, incidental, or consequential damages resulting from the use of any of the products or information contained or described on this publication. Further, we reserve the right to revise or otherwise make product improvements at any time without notification.

Fluid Connections

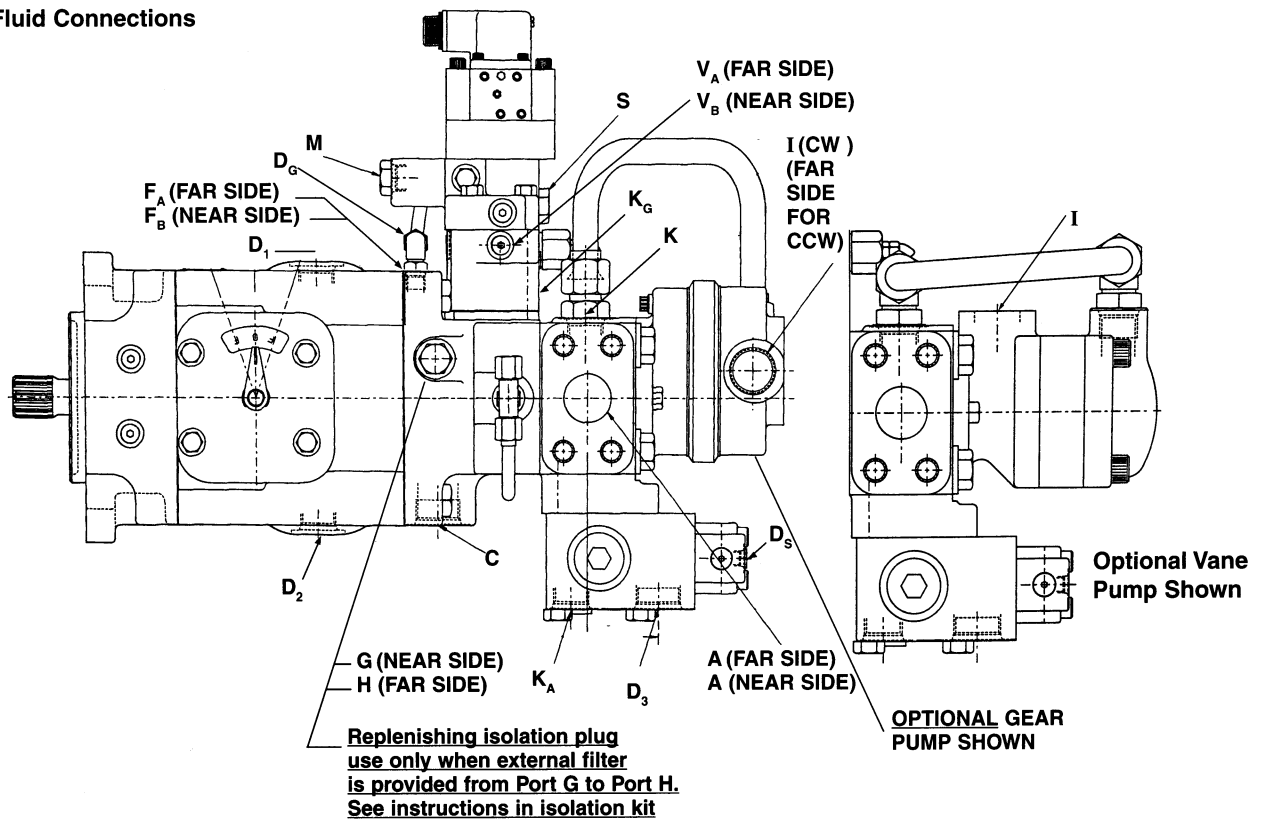

port	size	function
A	1 1/2" 4 bolt SAE 6000 psi	inlet/outlet
AG, BG	SAE - 6 straight thread	system pressure gage, ea. side
B	1 1/2" 4 bolt SAE 6000 psi	outlet/inlet
C	SAE - 16 straight thread	internal auxiliary pump inlet
D1, D2	SAE - 12 straight thread	case drain
D3	SAE - 16 straight thread	replenishing relief drain
DG	SAE - 6 straight thread	case pressure gage
DS	SAE - 4 straight thread	shuttle repl. pilot drain (ext.drain)
FA, FB	1/4 - 18 dryseal NPTF	control pressure gage, ea. side
G	SAE - 8 straight thread	int. aux. pump outlet to filter
H	SAE - 8 straight thread	filter return
I	SAE -16 straight thread	inlet to optional pump (gear pump)
	SAE - 1 1/4 3000 psi, 4-bolt pad	optional - vane pump
K	SAE -16 straight thread	aux. replenishing port
KA	SAE - 12 straight thread	aux. repl. inlet to shuttle
KG	SAE - 6 straight thread	replenishing pressure gage
M	SAE - 8 straight thread	auxiliary servovalve drain
S	SAE - 8 straight thread	servovalve inlet
VA/VB	SAE - 4 straight thread	individual compensator vent

Conversion Adapter Kit "A" mount S23-12438-0  
 "B" mount S23-12669-0

## INSTALLATION

### GENERAL

The **DENISON HYDRAULICS** Goldcup 6, 7, and 8 axial piston pumps feature advance design concepts which are time proven and provide for advance pumping and control concepts. The instructions contained in this manual cover complete disassembly and reassembly of the unit. Before proceeding with the disassembly or reassembly of any unit, this manual should be studied in order to become familiar with proper order and parts nomenclature.

### DESCRIPTION

The use of a rocker cam to control the pump displacement provides a small package size, reduces wear, and speeds control response. The control vane actuator eliminates linkage and backlash inherent in typical stroking cylinder designs.

Standard controls for the Goldcup units are Rotary Servo and Compensator Override. Additional optional controls are also available.

### MOUNTING

This pump is designed to operate in any position. The mounting hub and four bolt mounting flange are in full conformance with SAE standard. The pump shaft must be in alignment with the shaft of the driven load and should be checked with a dial indicator. The mounting pad or adaptor into which the fluid pump pilots must be concentric with the pump shaft to prevent bearing failure. This concentricity is particularly important if the shaft is rigidly connected to the driven load without a flexible coupling.

### SHAFT INFORMATION

**Splined:** The shafts will accept a maximum misalignment of 0.006" TIR (.15 mm). Angular misalignment at the male and female spline axes must be less than  $\pm .002$ " per inch radius (.002 mm per mm radius). The coupling interface must be lubricated. **DENISON HYDRAULICS** recommends lithium molybdenum disulfide or similar grease. The female coupling should be hardened to 27-45 Rc and must conform to SAE-J498B (1971) Class 1 flat root side fit.

**Keyed:** High strength heat treated keys must be used. Replacement keys must be hardened to 27-34 Rc. The key corners must be chamfered .030"-.040" (.75-1 mm) at 45° to clear radii that exist in the keyway.

**Splined or Keyed:** Both types of shafts will accept a side load of 170 lbs. (77 kg) at the center of the spline or key, with a B10 life of 10,000 hours at 1800 RPM.

### PIPING

Connect inlet and outlet lines to the port block of the pump.

The maximum case pressure is 75 PSI (5.17 bar) continuous, 125 PSI (8.6 bar) intermittent. Case pressures must never exceed inlet pressure by more than 25 PSI (1.7 bar). When connecting case drain line make certain that drain plumbing passes above highest point of the pump before passing to the reservoir. If not, install a 5 PSI (.3 bar) case pressure check valve to be certain the case is filled with oil at all times.

The case leakage line must be of sufficient size to prevent back pressure in excess of 75 PSI (5.7 bar) and returned to the reservoir below the surface of the oil as far from the supply suction as possible. All fluid lines, whether pipe, tubing, or hose must be adequate size and strength to assure free flow through the pump. An undersized inlet line will prevent the pump from reaching full speed and torque. An undersized outlet line will create back pressure and cause improper operation. Flexible hose lines are recommended. If rigid piping is used, the workmanship must be accurate to eliminate strain on the pump port block or to the fluid connections. Sharp bends in the lines must be eliminated wherever possible. All system piping must be cleaned with solvent or equivalent before installing pump. Make sure the entire hydraulic system is free of dirt, lint, scale, or other foreign material.

**Caution:** Do not use galvanized pipe. Galvanized coating can flake off with continued use.

### SERVICE INFORMATION

These hydraulic products are designed to give long dependable service when properly applied and their systems properly maintained. These general instructions apply to typical systems. Specific instructions for particular equipment can be developed from them.

### RECOMMENDED FLUIDS

See **DENISON HYDRAULICS** bulletin SPO-AM305 for more details.

## **FILLING CASE**

It is essential to make certain that the case (pump housing) is as full of fluid as possible and remains full during operation and at rest.

Always fill to the highest available point. Remove a plug or screw and allow the oil to escape through this point.

Recommended fill points:

Mounting orientation vertical, shaft up. D1 or D2 (drain) port in housing  
Vent DG2 port in mounting flange (new units)  
or one of the upper screws which attach the  
control. See installation drawing.

Vertical, shaft down <sup>1)</sup> or horizontal  
drain ports to the side D1 or D2 (drain port in housing.  
<sup>1)</sup> Vent DG (case gage) port in port block.

## **MAINTENANCE**

This pump is self-lubricating and preventative maintenance is limited to keeping system fluid clean by changing filters frequently. Keep all fittings and screws tight. Do not operate at pressures and speeds in excess of the recommended limit. If the pump does not operate properly, check the Trouble Shooting Chart before attempting to overhaul the unit. Overhauling is relatively simple and may be accomplished by referring to the Disassembly, Rework Limits of Wear Parts and Assembly Procedures.

## **FLUID CLEANLINESS**

Fluid must be cleaned before and continuously during operation by filters that maintain a cleanliness level of NAS 1638 Class 8.

## **START UP PROCEDURE**

- Read and understand the instruction manual. Identify components and their function.
- Visually inspect components and lines for possible damage.
- Check reservoir for cleanliness and drain and clean as required.
- Check fluid level and fill as required with filtered fluid at least as clean as that recommended. Fill pump case with clean oil prior to starting.
- Check alignment of drive.
- Check oil cooler and activate it, if included in circuit. Check fluid temperature.
- Reduce pressure settings of relief valve. Make sure accurate pressure readings can be made at appropriate places.
- If solenoids in system, check for actuation.
- Start pump drive. Make sure pump and motor fill properly.
- Bleed system of air. Recheck fluid level.
- Cycle unloaded machine at low pressure and observe actuation (at low speed, if possible).
- Increase pressure settings gradually in steps. Check for leaks in all lines especially in pump and motor inlet lines.
- Make correct pressure adjustments.
- Gradually increase speed. Be alert for trouble as indicated by changes in sounds, system shocks and air in fluid.
- Equipment is operational.

**TROUBLESHOOTING**

Component problems and circuit problems are often inter-related. An improper circuit may operate with apparent success but will cause failure of a particular component within it. The component failure is the effect, not the cause of the problem.

This general guide is offered to help in locating and eliminating the cause of problems by studying their effects:

<b>effect of trouble</b>	<b>possible cause</b>	<b>fault which needs remedy</b>
noisy pump	air in fluid	leak in suction line leak at shaft seal low fluid level turbulent fluid return lines above fluid level gas leak from accumulator excessive pressure drop in the inlet line from a pressurized reservoir suction line strainer acting as air trap
	cavitation in pump or motor rotating group	fluid too cold fluid too viscous fluid too heavy shaft speed too high suction line too small suction line collapsed suction strainer too small suction strainer too dirty operating altitude too high boost or replenishment pressure too low replenishment flow too small for dynamic conditions
	misaligned shaft	faulty installation distortion in mounting axial interference faulty coupling excessive overhung loads
	mechanical fault in pump	piston and shoe looseness or failure bearing failure incorrect port plate selection or index eroded or worn parts in the displacement control
erosion on barrel ports and port plate	air in fluid	see above
	cavitation	see above
high wear in pump and motor	excessive loads	reduce pressure settings reduce speeds
	contaminant particles in fluid	improper filter maintenance filters too coarse introduction of dirty fluid to system reservoir openings improper reservoir breather improper line replacement

## TROUBLESHOOTING

### TROUBLESHOOTING (continued)

effect of trouble	possible cause	fault which needs remedy
high wear in pump and motor (continued)	Improper fluid	fluid too thin or thick for operating temperature range breakdown of fluid with time/temperature/shearing effects incorrect additives in new fluid destruction of additive effectiveness with chemical aging
	improper repair	incorrect parts incorrect procedures, dimensions, finishes
	unwanted water in fluid	condensation faulty breather/strainer heat exchanger leakage faulty clean-up practice water in makeup fluid
pressure shocks	cogging load	mechanical considerations
	worn relief valve	needed repairs
	worn compensator	needed repairs
	slow response in check valves	replace or relocate
	servo pressure too low to maintain firm control	increase pressure and check pressure drop through servo filter
	excessive decompression energy rates	improve decompression control
	excessive line capacitance (line volume, line stretch, accumulator effects)	reduce line size or lengths eliminate hose
	barrel blow-off	re-check pump hold-down, rotating group, drain pressure
heating of fluid	excessive pump or motor leakage	recheck case drain flow and repair as required fluid too thin improper assembly, port timing
	relief valve	set too low (compared to load or to compensator) instability caused by back pressure, worn parts
	compensator	set too high (compared to relief) worn parts
	pump too large for fluid needs	select smaller pump displacement
	heat exchanger	water turned off or too little flow water too hot fan clogged or restricted efficiency reduced by mud or scale deposits intermittent hydraulic fluid flow
	reservoir	too little fluid entrained air in fluid improper baffles insulating air blanket that prevents heat rejection heat pickup from adjacent equipment



T-1

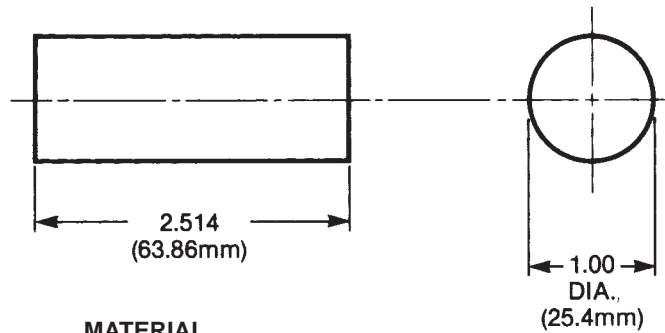

**MATERIAL**  
CRS 1" DIA. X 2 5/8"  
(25.4mm) (66.68 mm)

T-2

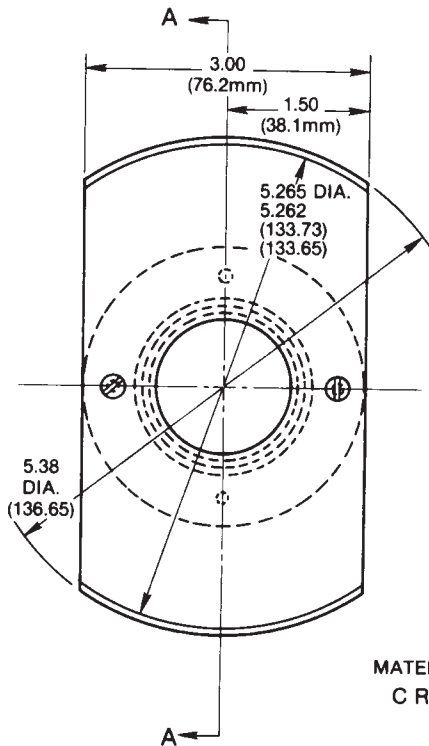

**MATERIAL**  
C R S

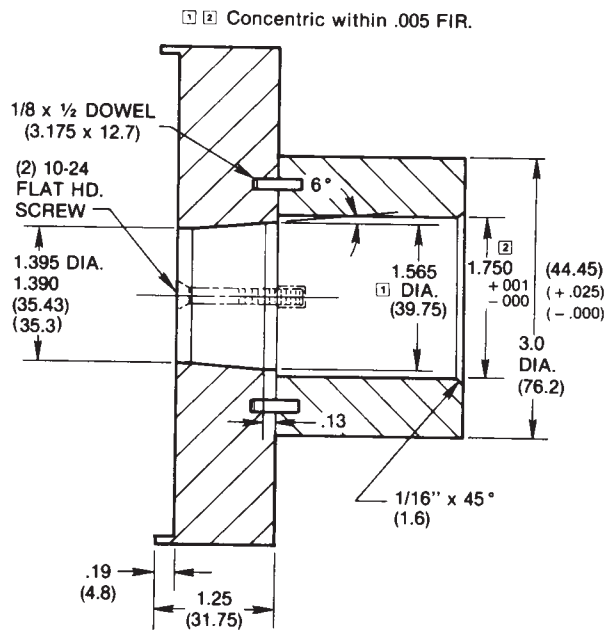

**Note:** Dimensions in ( ) are mm.

T-3

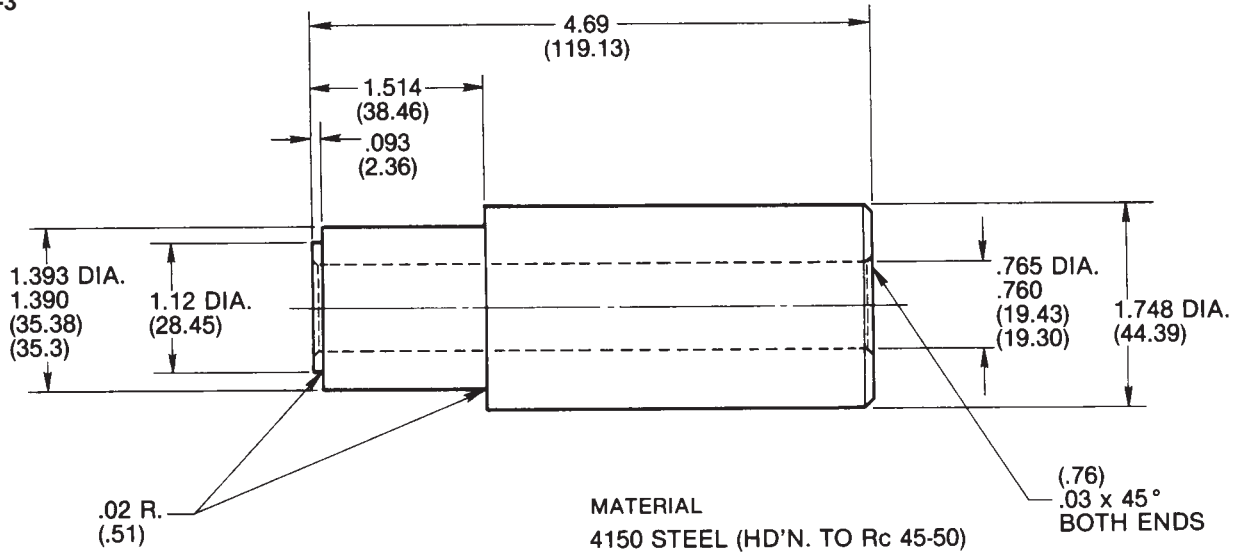

T-4

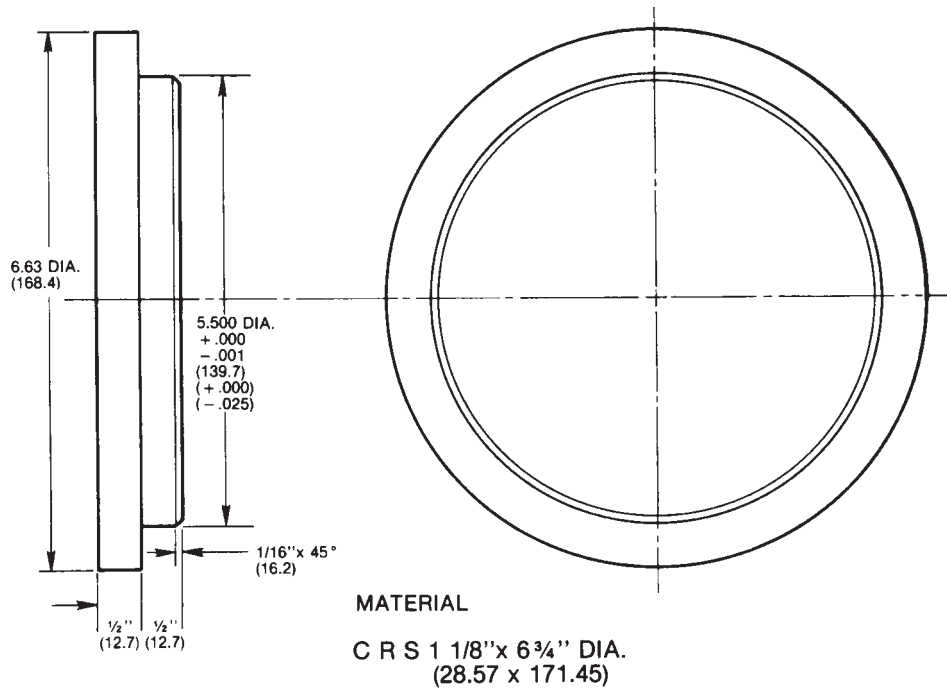

T-5

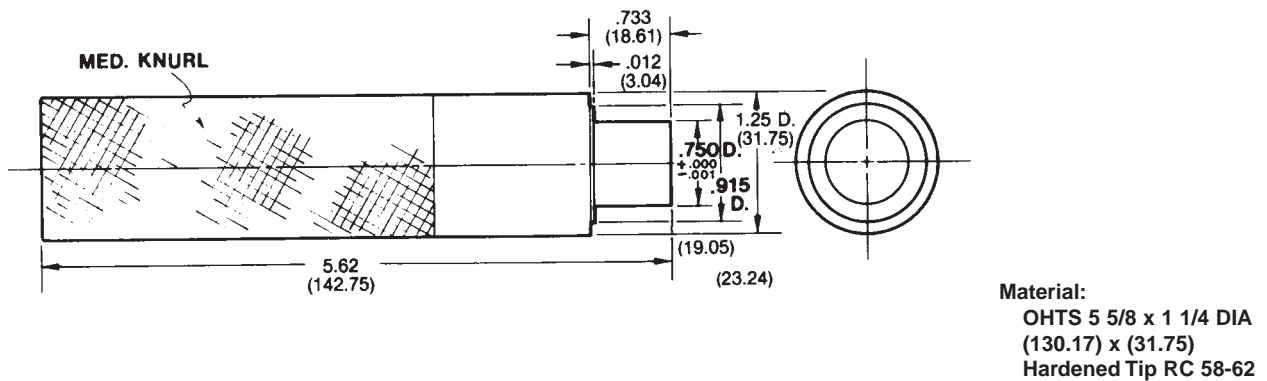

Note: Dimensions in ( ) are mm.

## INTRODUCTION

The instructions contained in this section cover a complete teardown of the subject pump. Disassemble only as far as necessary to replace or repair any worn parts.

## DISASSEMBLY

Position pump unit so that valve block assembly is on top. A bench or similar suitable surface capable of supporting unit should be used. Disassembly area should be clean.

## VALVE BLOCK

**See figure 14.** Remove the eight hex. head cap screws (17) and lift the entire block assembly from the port block.

**See figure 12/13.** Remove the four hex. head cap screws (58) and four soc. hd. screws (53) and lift the entire block assembly from the port block.

*(before 7-93)*

**See figure 10.** Remove the four screws (39) to separate the cover (21) from the block (11). Do not remove the check valves (19).

Remove plugs (43), (36) and pin (40). Remove the 8-32 nut from the bottom of cover (21) to remove filter assembly (34).

Remove housing (29) and O-ring (28). Remove items (30), (31), (32) and (33) as a unit. Insert a small brass rod thru the hole in the housing and tap out piston (27) and O-ring (26).

Remove spring (25) and cone (24). Remove seat (23) and O-ring (22).

**Note:** Seat is made for hex. wrenching. Use 1/2" six point socket with 1/4" drive.

Remove O-ring (37) and replenishing relief valve (41). Inspect orifices (12) visually to insure they are open. Do not remove unless damage or clogging is apparent.

Remove springs (16), (17) and (18). Remove retainer (15) and poppets (13) and (14).

Remove the four screws (4) from the plate (6) and (11). Remove gasket (7).

Remove seats (8) and (9). Do not remove roll pins (5) and (10) unless replacements are needed.

*(after 7-93)*

**See figure 11.** Remove plugs (20), (23) and pin (21). Remove the 8-32 nut from the bottom of block (1) to remove filter assembly (14). Do not remove the check valves (2).

Remove housing (8), O-ring (9), piston seal (10), O-ring (11), screw (6), nut (7), and acorn nut (45) as a unit.

Remove spring (12) and cone (13). Remove seat (5) and O-ring (4).

**Note:** Seat is made for hex. wrenching. Use 1/2" six point socket with 1/4" drive.

Remove plug (25) and replenishing relief valve (36).

Remove O-rings (37), (48) and (47). Remove four screws (43) and remove the retainer plate (42). Do not remove roll pins (46) unless replacements are needed.

Remove gasket (29) and seats (27) and (28). Remove poppets (30), (31) and springs (32), (33), (35) and retainer (34).

Inspect orifices (3) visually to insure they are open. Do not remove unless damage or clogging is apparent.

## CONTROLS

**See figure 14.** Remove the four screws (14) from the side cover (16) and remove the input shear seal valve assembly

**Note:** The mylrite washers (13) should be replaced at assembly.

Remove the four screws (14) from the side cover (15) and remove the counter balance shear seal assembly.

Remove the two screws (12) and remove the balance stem (9) and balance plate (10)

## EXTERNAL PUMP, SHUTTLE VALVE AND REAR ADAPTER

**See figure 14.** Remove two screws (20) and remove external pump (21).

Remove four screws (23) and remove shuttle valve (24).

Remove four screws (9) fig. 15 and remove adapter (22).

## BARREL HOLDDOWN AND GEROTOR ASSEMBLY

**See figure 9.** Remove retainer ring (16), pin (14), holddown nut (13), insert (15), thrust washers (10), bearing (11) and seal ring (12).

Remove pressure plate (9), Gerotor side plate (5) "O" rings (7) and (8).

Remove Gerotor assembly (3), dowel pin (4), key (2), and side plate (1).

**PORT BLOCK**

**See figure 8.** Remove four screws (1) that secure the port block (2) to the housing (6). Use caution when removing screws on valve block side to prevent marring valve block face.

Remove port block (2) and gasket (5). Remove port plate (4) and port plate pins (3).  
**Note:** port plate will in some instances adhere to port block upon disassembly.

**See figure 7.** Remove the check valve assemblies (7) from the port block.

Remove needle bearing (2) from the port block.

Remove two screws (5), lockwashers (6), check rings (3), and clamps (4). Only one check ring assembly in open circuit pumps.

**BARREL AND AUXILIARY SHAFT**

Remove face plate (2, fig. 6) from face of barrel assembly.

Remove the barrel assembly (1, fig. 4) by grasping the auxiliary shaft and lifting the complete assembly out of the housing.

**DRIVE SHAFT**

**See figure 14.** Remove the four screws (8) and gaskets (7). Remove seal retainer (6), and the stationary part of the shaft seal (4). Refer to view of item 4.

Carefully remove the carbon ring and the remainder of the shaft seal from the shaft.

**Caution:** Do not scratch seal surface of shaft when removing seal.

Remove snap ring (3) and the shaft and bearing assembly (1). Remove shim (2).

**HOUSING**

After shaft assembly has been removed, position the unit on end with the mounting flange turned down.

Push the ends of the small tube lines away from the housing.

Lift the housing from the mounting flange, remove the gasket, and dowel pins from the mounting flange.

Do not remove the roll pins and the bearing from the housing unless the bearing is damaged and must be replaced.

**ROCKER CAM AND CONTROL STROKING ASSEMBLY**

**See figure 4.** Remove the complete assembly (5) from the mounting cap (7) and position on a clean flat surface with the two tubes (2) in a horizontal position and located at the top. Mark the cam (24) and cradle (20) as indicated in Figure 3. These marks will determine positioning of parts during reassembly.

Carefully remove the small tube lines (3) and (4) from the cradle.

**Caution:** Do not bend these lines

**See figure 3.** Position the assembly in an upright position on the flat surface of the cradle (20). Remove the retaining ring (1) and thrust washer (2). Remove the piston and shoe assembly (4) and the creep plate (5) from the cam (24). Carefully remove the two set screws (6a) and two screws (6) that secure the servo plate to the cam (24) and remove the servo input parts (7, 8 and 9).

Remove the four 7/16" screws (10) and eight 1/4" screws (11) and (12) from the control covers (15R) and (15L). Remove the four dowel pins (16) and remove the two chambers (17). Remove the two special seals (18) and the four steel balls (19). Remove the two vane seal cartridge assemblies (23) and the four holddown vanes (22) from the rocker cam (24).

**Note:** Some units may have thin shims under the holddown vanes.

Remove the rocker cam (24) from the cradle (20).

**Caution:** Do not remove the plugs from the rocker cam.

**REWORK LIMITS OF WEAR PARTS**

<b>6, 7.25 and 8.0 in<sup>3</sup></b>	<b>max. rework from original</b>	<b>min. dimension after rework</b>
port plate face	.010" (0,254 mm)	.295" (7,49 mm)
shoe retainer face	.005" (0,127 mm)	.307" (7,8 mm)
piston shoe face (pocket)	.006" (0,152 mm)	.008" (0,2 mm)
creep plate face	.005" (0,127 mm)	.286" (7.13 mm)
face plate	none	replace

**IMPORTANT:**

The port plate both faces finish must be 25 microinches (635 mm), flat within .00006 (0015 mm) and parallel within .001(0254 mm) T.I.R.

The creep plate wear face finish must be 10 microinches (254 mm), flat within .0002 (0381 mm) and parallel to the backside within .0005 (0127 mm)T.I.R.

The shoe retainer wear face finish must be 32 microinches (813 mm), and flat within .0015 (0381 mm) (must not be convex).

The piston shoes wear face finish must be 5 microinches (127 mm), and must be lapped in a set with the retainer plate, all shoe sole thicknesses to be within .001 (0254 mm) after lapping. The maximum permissible shoe and piston axial looseness is .010 (254 mm).

The special retaining ring service kit (S23-12461) may be required to control shoe holddown clearance.

**CLEANING AND INSPECTION**

All parts must be inspected and be free of material defects, dirt, scratches or any foreign material.

All parts must be cleaned with a suitable cleaning solvent and all holes and passages blown out with dry, clean, compressed air.

After cleaning and inspection, all parts must be covered with a light film of oil and protected from dirt and moisture. Excessive handling of internal parts should be avoided prior to assembly.

During assembly, lapped and ground surfaces must be lubricated with clean oil and protected from nicks or surface damage.

**DRIVE SHAFT AND BEARING**

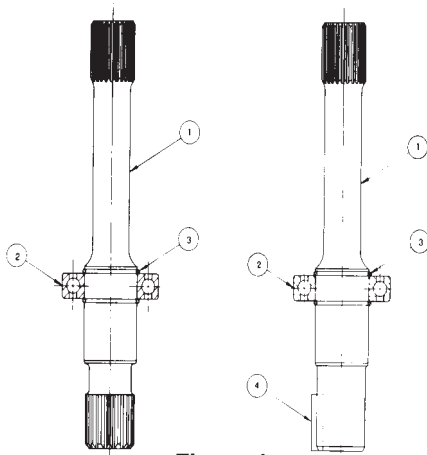

Figure 1

**See figure 1.** Pass one retaining ring (3) over the internal end of drive shaft (1) and install in the groove near the shaft seal surface.

**Caution:** Do not pass the ring over the seal surface.

Press the bearing (2) over the same end of the shaft and seat against the ring. *Support only the inner race of the bearing and press on the coupling end of the shaft.*

**Caution:** Do not use excessive force and distort or damage the retaining ring.

Install the other retaining ring (3) in the other retaining ring groove. Be sure that both rings are fully seated.

**PARTS LIST FOR FIGURE 1**  
**S13-41805 DRIVE SHAFT ASSEMBLY (SPLINED)**  
**S13-41806 DRIVE SHAFT ASSEMBLY (W/KEYWAY)**

item	description	part no.	quantity	
			#3	#2
1	#3 (splined shaft)	033-70567	1	-
	#2 (keyed shaft)	033-70579	-	1
2	shaft bearing	230-82140	1	1
3	retaining ring	033-70817	2	2
4	square key 5/16 x 1-1/4	033-71348	-	1

**BARREL AND AUXILIARY DRIVE SHAFT**

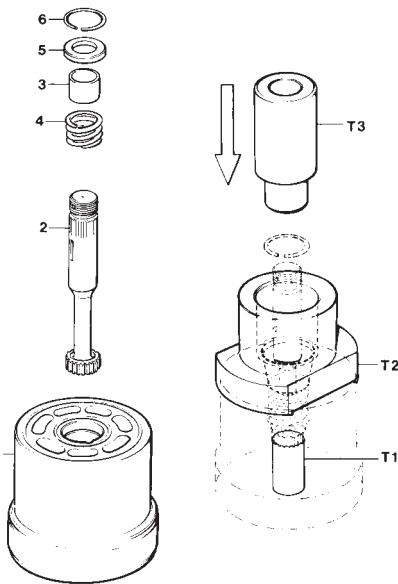

Figure 2

**See figure 2.** Position the barrel (1) in a press with the large end turned down and insert tool figure T-1 in the splined shaft hole in the barrel.

Place stop (3) and spring (4) over shaft (2) in the same sequence as shown.

Insert shaft (2) in barrel (1) and rest on tool figure T-1. Position the spring retainer (5) over the shaft (2) and against spring (4).

Carefully place tool figure T-2, with the large end of the tapered hole up, over the shaft (2) and against the barrel face (1). Insert ring (6) around the shaft (2) and in the tool.

Position the ring with the gap within 5/8" (16 mm) of the notch in the barrel for easy removal.

Place tool figure T-3 over the shaft (2) with the small end against ring (6). Press on the end of the assembly tool and seat the ring (6) in the groove of the barrel (1).

Remove the assembly tools. Check to be sure that the ring is properly seated. Check barrel face to be certain it is not marred.

**PARTS LIST FOR FIGURE 2**  
**S23-12363 P6 COMPLETE BARREL AND SHAFT ASSEMBLY**  
**S23-12500 P7 COMPLETE BARREL AND SHAFT ASSEMBLY**  
**S23-12717 P8 COMPLETE BARREL AND SHAFT ASSEMBLY**

item	description	part no.	quantity		
			P6	P7	P8
1	barrel & sleeve ass'y (P6)	S13-43657	1	-	-
	barrel & sleeve ass'y.(P7)	S13-47511	-	1	-
	barrel & sleeve ass'y (P8)	S23-12718	-	-	1
2	auxiliary drive shaft	033-91050	1	1	1
3	stop	033-53944	1	1	1
4	barrel holddown spring	033-70493	1	1	1
5	spring retainer	033-53945	1	1	1
6	retaining ring	033-70494	1	1	1

Consult **DENISON HYDRAULICS** Service for parts prior to 1983 units.

## ASSEMBLY PROCEDURES

### PARTS LIST FOR FIGURE 3 rocker cam, pistons and retainer

item	description	part no	qty.
1	retaining ring (yellow) .083" (2.11 mm)	033-70484	1
	retaining ring (green) .081" (2.06 mm)	033-70488	
	retaining ring (red) .079" (2.01 mm)	033-70490	
	retaining ring (white) .087" (2.21 mm)	033-72175	
	retaining ring (blue) .085" (2.16 mm)	033-72176	
	retaining ring (black) .077" (1.96 mm)	033-54826	
	retaining ring service kit	S23-12461	
2	thrust washer	033-72249	1
3	not used		
4	piston & shoe assy. w/retainer	See below	
5	creep plate	033-71261	1
6	button hd. screw	353-25041	2
6a	setscrew, 2 ea.	312-09032	2
7	servo stem	033-71312	2
8	orifice screw	033-70819	2
9	servo plate	033-53874	1
*10	hex. hd. screws 7/16-14 x 2-1/2	306-40183	4
*11	hex. hd. screws 1/4-20 x 1-1/4	306-40188	4
*12	hex. hd. screws 1/4-20 x 2-1/4	306-40187	4
*13	hex socket plug SAE-4	488-35001	2
*14	O-ring 90-6290-4	691-00904	2
*15R	right side chamber cover CW rot.	033-70572	1
	right side chamber cover CCW rot.	033-70612	
*15L	left side chamber cover CW rot.	033-70571	1
	left side chamber cover CCW rot.	033-70574	
*16	dowel pin 1/4 x 1-1/2	324-21624	4
*17	chamber	033-72266	2
*18	seal	606-25036	2
*19	steel ball 3/16	201-06001	4
*20	rocker cradle	033-53951	1
*22	hold down vane	033-70816	4
*23a	-seal backup plate	033-70802	4
*23b	-vane seal	033-70501	2
*23c	-O-ring 90-914-20	691-00120	2
*23d	-spacer	033-70519	2
*23e	-check valve	033-70803	2
*24	rocker cam	S23-12105	1
25	pressure tube	033-70524	2

**\*Note:** Item 10 through 24 can be ordered as a complete rocker cam & control stroking assembly.

S23-12196 is for RH pumps

S23-12197 is for LH pumps

item	description	P6S	P7S	P8S	qty.
4	piston & shoe assy. w/retainer	S13-43655	S13-42308	S21-11650	1
4a	shoe retainer	033-54290	033-54290	033-57376	1
4b	piston & shoe assy.	S13-45680	S13-46040	S21-11649	7

ROCKER CAM/PISTONS  
AND RETAINER

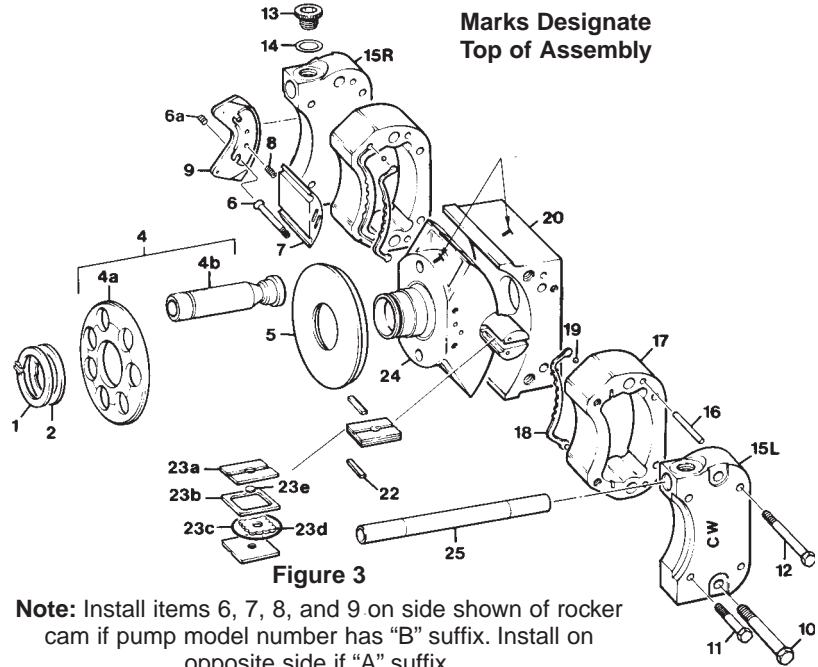

ROCKER CAM

See figure 3. Position the cradle (20) on a clean flat surface with the large flat area down.

Position the rocker cam (24) on the cradle (20). Note marks made earlier to indicate top of rocker cam & cradle.

Place O-ring (23c) around spacer (23d) and insert in the vane seal (23b). Insert check valve (23e) inside of spacer (23d) and assemble between the two backup plates (23a) with the notched V's exposed.

Install assembled cartridge in slot in cam as indicated in Figure 3. Repeat steps 1, 2 and 3 on other side of cam.

Insert the four holddown vanes (22) in the slots on each side of the control vanes (23).

Position both control chambers (17) on a clean flat surface with seal grooves turned up. Drop the four steel balls (19) in the four counterbored holes at each end of the seal grooves.

Lubricate seals (18) and insert in seal grooves in control chamber (17).

The tapered side of the seals must be pushed into the grooves and the ends must cover the steel balls.

Install the control chamber (17) with seal (18) and steel balls (19) assembled over the control vane (23). The seal must be against the cam. Rotate the chamber until it passes over the control vane assembly, then rotate in the opposite direction until the 1/4" dowel pins (16) can be pushed through the chamber (17) and into the cradle (20). Install chamber in the same manner on the other side of the cam.

Two sets of chamber covers are available. The set marked CW must be installed in the right hand rotation pump and the set marked CCW must be used in the left hand rotation pump. (Rotation is determined facing the shaft end of pump.) The covers must be installed with the tubing holes and the tapped holes at the top of the unit. Install chamber covers (15r) and (15l) on the control chambers (17) over the dowel pins (16). The tapped holes must be at the top. Refer to the "T" marked on the rocker cam (24) and cradle (20).

Install four 1/4-20 screws, two (11) and two (12), in each side and torque to 10 ft.-lbs. (13.56 Nm)

Install two 7/16-14 screws (10) in each side and torque to 45 ft.-lbs. (61.0 Nm)

Install O-ring (14) and plug (13) in each cover.



**ROCKER CAM**

(continued)

Install tubes (25) in reamed holes in each cover. These tubes must be a tight fit. If tubes are loose, the ends can be expanded with a tapered punch.

Tap the tubes in place with a plastic mallet.

Install two orifice screws (8) in the servo stem (7).

Install servo plate with the end of the screws (6) through the servo stem. The orifice screw end of the servo stem must be against the servo plate.

Position the stem and plate on the rocker cam input side at 9 o'clock position on "B" suffix or 3 o'clock on "A" suffix models with the screws positioned over the 10-24 tapped holes. Torque the screws (6) to 40 in. lbs. (4.5 Nm). Install setscrews (6a) and torque to 5 ft.-lbs. (6.8 Nm). **Caution:** The set screws must not protrude from the servo plate.

Install creep plate (5) over center post on rocker cam with small O.D. of plate turned toward cam.

**PISTONS AND SHOES**

**See figure 3.** Insert the seven piston and shoes (4b) in the shoe retainer (4a). Position the assembly (4) over the center post and against the creep plate.

Install thrust washer (2), over center post.

Five different retaining rings (1) are available for the holddown assembly. Each ring is marked; white dot .087 (2.21 mm) thick, blue dot .085 (2.16 mm) thick, yellow dot .083 (2.11 mm) thick, green dot .081 (2.06 mm) thick, and red dot .079 (2.01 mm) thick. Install the thickest ring (1) with the dot up, that will fit in the groove on the center post and allows a maximum clearance of .002-.004 (.051-.102 mm) between the shoe and creep plate while grasping one piston and lifting tightly against shoe retainer.

The piston and shoe assembly (4) must be free to rotate easily by hand. The assembly must be rotated through 360° to confirm there is no binding and that each shoe is always free in the retainer plate. Oil the assembly thoroughly.

Position the cradle and cam assembly with the piston and shoe assembly attached with T marked on the cradle turned up.

**See figure 4.** Insert tube line assemblies (3 and 4) in the holes provided in cradle.

**Note:** Tube assemblies (3 & 4, fig. 4) must be a snug fit into holes in cradle. Expand end of tubes with a pointed tool to assure fit.

Position the mounting flange (7) with the large open end up, and install two dowel pins (6) in the cradle mounting surface of the flange and two dowel pins (6) in the outer edge of the flange.

Install rocker cam and cradle assembly over the two dowel pins (6) in the mounting flange. Be certain that cradle is seated over the pins and against the flange with the tube lines (3) and (4) in the grooves in the flange.

Position the mounting flange with the rocker cam assembly installed on the top or bottom side and install two or more 1/4-20 x 1-1/4" screws through the seal retainer area into the cradle. Be certain the cradle is fully seated in flange. These screws are required to hold the rocker cam assembly in place and will be removed later.

Return the assembly to an upright position with the mounting flange down.

Tilt the rocker cam to either extreme position in the cradle.

Position the Barrel Assembly with Auxiliary Shaft (1) directly over the pistons. Start with the uppermost piston and guide them one at a time into the barrel. Return the rocker cam to a level position in the cradle.

**MOUNTING, FLANGE, CAM & CRADLE, BARREL**

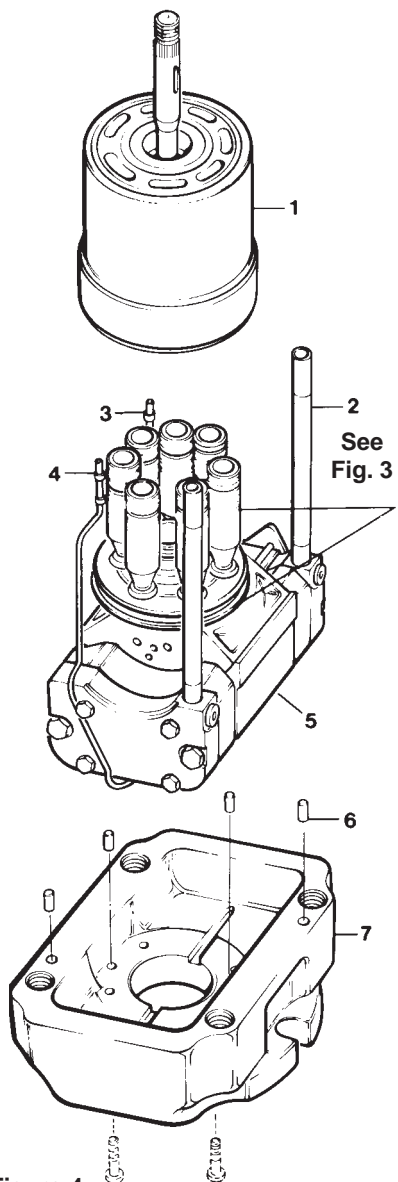

Figure 4

**PARTS LIST FOR FIGURE 4**

item	description	part no.	qty.
1	barrel and auxiliary shaft assy.	See fig. 2	1
2	pressure tube	033-70524	2
3	tubing assy. (right side)	S13-42402	1
4	tubing assy. (left side)	S13-42403	1
5	rocker cam and stroking assy.	See fig. 3	1
6	dowel pin 3/8" X 3/4"	324-22412	4
7	mounting flange	033-70604	1

**HOUSING**  
S13-42335

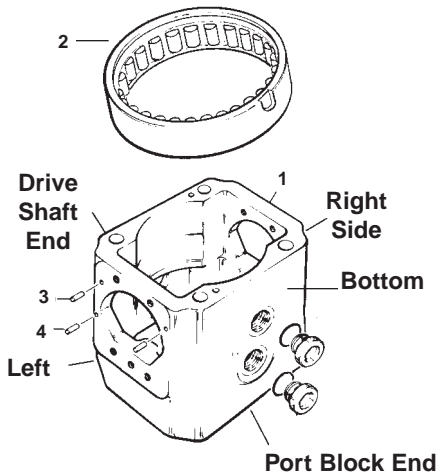

Figure 5

See figure 5. Position housing (1) on a clean flat surface with the large open end up.

Wash and dry all parts. During assembly, lapped and ground surfaces should be kept lubricated with clear oil and protected from nicks or surface damage.

Clean housing, item #1, and barrel bearing, item #2. Apply loctite primer grade "T" & loctite retaining compound #609 to bearing O.D. & bearing bore of housing. Rest housing on mounting flange end.

Position notch on bearing (2) with hole in housing bore. Insert Pressing Plug tool (figure T-4) in the bearing. With smooth and steady force, press the bearing into the housing bore until seated. **DO NOT HAMMER OR BEAT INTO PLACE.**

Install bearing retainer (7) with O-ring (8). Torque to 50 lb.-ft. (68 Nm).

Turn housing (1) on side and install roll pin (4) in the 1/4" through hole in the control cover pad. The pin must be 3/8" below the pad surface. **THE PIN END MUST NOT INTERFERE WITH THE INTERNAL BEARING CAGE.** Install two dowel pins (3) in the blind holes in the same pad.

Repeat the above step on the opposite side of the housing.

Place O-ring (5) on plug (6) and install in bottom of housing (1). (Roll pins (4) are in bottom of housing.)

**PARTS LIST FOR FIGURE 5**

item	description	part no.	qty.
1	housing	033-91108	1
2	bearing	033-91107	1
3	dowel pin	324-21608	4
4	roll pin	325-16280	2
5	O-ring 90-6290-12	691-00912	1
6	hollow hex plug SAE-12	488-35014	1
7	retainer-bearing	033-91106	1
8	O-ring, 90 S-1 ARP 908	691-00908	1

**HOUSING, END CAP, CAM AND BARREL**

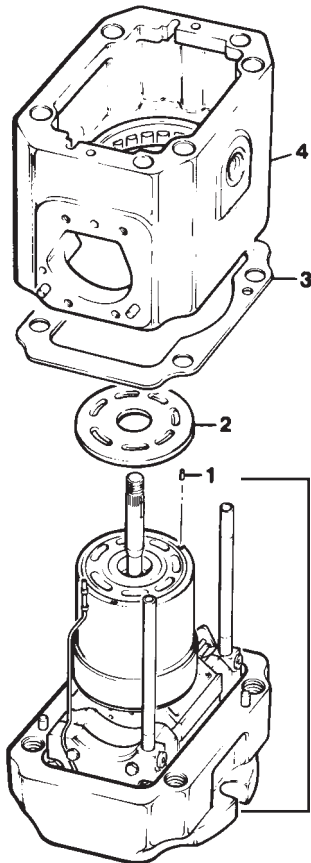

Figure 6

See figure 6. Insert the three face plate pins (1) in the holes provided in the barrel face.

Apply heavy grease to the face of the barrel and install the face plate (2) over the pins (1) in the barrel.

Make certain the face plate is properly seated on the barrel and pins with the steel side towards the barrel face. The face plates have only one side bronzed and this should be toward the port plate. If necessary, remove coating from edge of face plate to determine bronze side.

Install gasket (3) over the two dowel pins (item 6 on Fig. 4) in the mounting flange.

Position the Housing Assembly (4) over the Barrel and Auxiliary Shaft Assembly and carefully guide the pressure tubes and tube lines (items 2, 3 and 4 on Fig. 4) through the Housing Assembly (4).

**PARTS LIST FOR FIGURE 6**

item	description	part no.	qty.
1	face plate pins	033-49825	3
*2	barrel face plate 6 in <sup>3</sup> only	033-71530	1
	barrel face plate 7.25 and 8.0 in <sup>3</sup>	033-72532	1
3	housing gasket	033-91067	1
4	housing assembly	See fig. 4	1

\*Note: item 2: (Ref. only) Arcuate port width: 6 in<sup>3</sup> is 13/32" (10,3 mm), 8.0 & 7.25 in<sup>3</sup> is 1/2" (12.7 mm)

See Fig. 4

PORT BLOCK

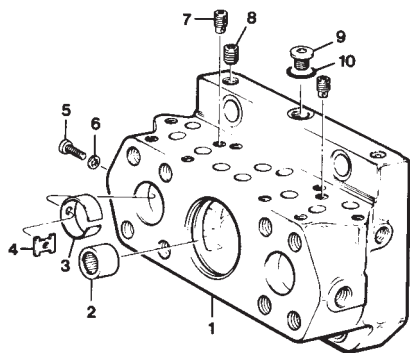

Figure 7

See figure 7. Position the port block (1) on a clean flat surface with the two open ports up. THE OPPOSITE FACE MUST NOT BE SCRATCHED OR DAMAGED. Position needle bearing (2) on tool (Figure T-5) with the marked end of the bearing against the shoulder on the tool and press the bearing (2) into the port block. The bearing must be .010-.025" (.254-.635 mm) below the surface.

Slip check ring (3) into the two 1.50" (38 mm) ports and align holes in the ring with the side holes in the port wall.

Place lock washers (6) on special screws (5). Insert (5) through port wall and drilled holes in checks (3) and thread into clamps (4). Torque to 10 ft. lbs. (13.56 Nm).

Thread socket pipe plugs (8) into port block.

Thread two check valve assemblies (7) into valve face of port block.

Place O-ring (10) on hollow hex plug (9) and thread into tapped hole in top of the port block.

PARTS LIST FOR FIGURE 7

item	description	part no.	qty.
1	port block	033-71296	1
2	needle bearing	230-82146	1
3	check ring	033-70502	2
4	clamp	033-70489	2
5	special screw	033-70908	2
6	no. 10 lock washer	348-10016	2
7	check valve assy.	S13-40266	2
8	1/4 soc. pipe plugs	431-90404	2
9	hollow hex plug SAE-6	488-35041	1
10	O-ring 90-6290-6	691-00906	1

MOUNTING PORT BLOCK TO HOUSING

See figure 8 on next page. Position the pump with the unplugged hole (top drainport) in the housing assembly at 12 o'clock position.

Install gasket (5) on the housing assembly (6).

Install the two special pins (3) in the face of the port block assembly. Apply petroleum jelly or heavy grease to the plate (4) and position port plate over the pins (3) on the port block. Port plate must be fully seated and indexed towards direction of rotation. (See port plate view in figure 8.)

Slide the port block assembly and port plate over the end of the auxiliary shaft. Be certain that tubes 2, 3 and 4 shown on Fig. 4 are engaged and that the port plate (4) is still on the pins (3).

When the pump is properly assembled, the valve mounting surface will be at the top of the unit.

Install the four bolts (1), and torque to 225 ft.-lbs. (305 Nm). **Caution:** Use care to prevent damage to the valve mounting surface while installing and torquing the two top bolts.

PARTS LIST FOR FIGURE 8

item	description	part no.	qty.
1	hex head cap screw 5/8-11 x 9	306-40182	4
2	port block assy.	See Fig. 7	1
3	port plate pins	033-49825	2
4	RH port plate 6 in3	033-71526	1
	LH port plate 6 in3	033-71525	1
	RH port plate 7.25 in3	033-72811	1
	LH port plate 7.25 in3	033-53776	1
	RH port plate 8.0 in3	033-91252	1
	LH port plate 8.0 in3	033-91553	1
5	housing gasket	033-91060	1
6	housing Assy.	S13-42335	1
7	mounting flange	See Fig. 4	1

**MOUNTING PORT  
BLOCK TO HOUSING**

(continued)

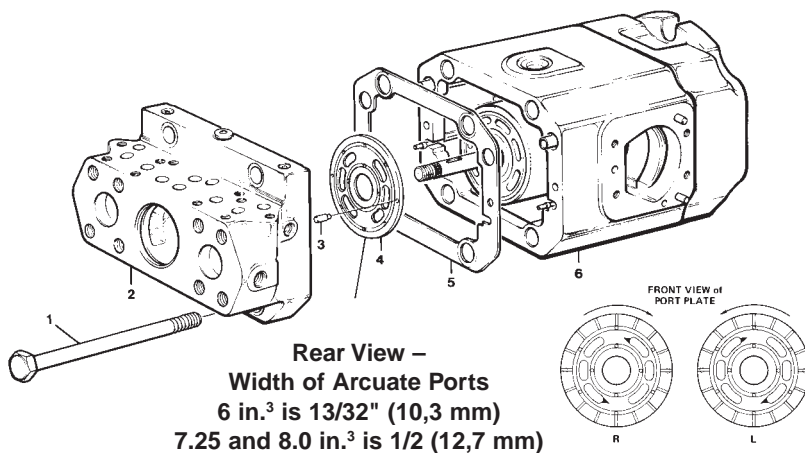

**Figure 8**

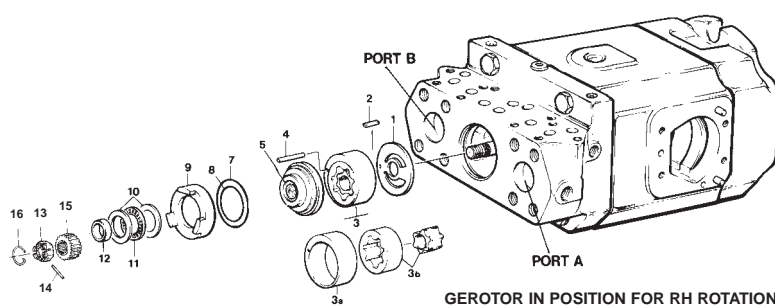

**Figure 9**

**GEROTOR AND BARREL  
HOLDDOWN**

**See figure 9.** Position the unit with the shaft in a horizontal position and the valve block mounting surface turned up. Rotate the shaft until the small keyway in the auxiliary shaft is at 12 o'clock.

If pump is being assembled for right hand rotation install dowel pin (4) in hole in port block at the 9 o'clock position; if left hand pump, install at 3 o'clock position when viewing from port block end of unit.

Install side plate (1), steel side first, over dowel pin. Insert key (2) in shaft keyway. Install the inner gear of the gerotor assembly (3b) on the shaft and over the key (2). Install the eccentric ring (3a) on the dowel pin (4). Install the large outer gear of the gerotor assembly (3b) inside the eccentric ring (3a) and over the inner gear.

**Note:** When changing pump rotation consult parts list for proper side plate.

Place O-rings (7) and (8) on side plate assembly. Lubricate the O-rings and slip the pressure plate (9) over the O-rings on the side plate assembly. Slip the two plates over the auxiliary shaft and position the gerotor side plate over the dowel pin (4).

Place seal ring (12) on auxiliary shaft. Position bearing (11) between the two thrust washers (10) and install around the seal ring (12). Install insert (15) over spline on shaft. Thread holddown nut (13) on the shaft and tighten no more than 10 ft. lbs. (13.56 Nm) max. Back off the nut (13) until second slot is aligned with pin hole in the shaft. Insert pin (14) through nut and shaft and secure with ring (16).

Check the main shaft for smooth rotation. If not smooth, check the gerotor parts for position and hold down nut for proper adjustment.

PARTS LIST FOR FIGURE 9

item	description	part no.	qty.
1	side plate	033-71492	1
2	square key 1/8 x 9/16	211-22034	1
3	gerotor and eccentric ring assy.	S13-43334	1
3a	eccentric ring	033-72256	1
3b	inner and outer gerotor	033-71500	1
4	dowel pin 3/16 x 1-9/16	324-21225	1
*5	gerotor sideplate and bearing assy	See below	1.
7	O-ring 70-914-44	671-00144	1
8	O-ring 70-914-29	671-00129	1
9	pressure plate	033-70531	1
10	thrust washer	350-10081	2
11	bearing	230-82164	1
12	seal ring	033-72101	1
13	holddown nut	033-91052	1
14	pin	033-53921	1
15	insert	033-91051	1
16	retaining ring	033-53923	1

\* for RH pumps use S13-46762

\* for LH pumps use S13-46763

**VALVE BLOCK**

(before 7-93)

See figure 10.

**Note:** Prior to assembly of reconditioned parts, check finish of gasket surface on valve block and retainer. Must have 60 rms finish with no grinding marks which might carry oil to outside surface. If lapping is necessary, check depth of pockets for valve seats after lapping. Must be .085" (2.16 mm) minimum after lapping, to provide clearance for valve seats.

Lubricate the four orifice plugs (12) and insert in the top of valve block (11).

Check the pilot valve assembly (41) to be certain that approximately 1-1/2 threads are exposed from this small nut on the bottom of the valve assembly. This setting will allow the valve to function at about 200 PSI (14 bar). Each complete right hand turn of this screw will increase the pressure about 50 PSI (3.4 bar). Torque hex lock nut to 20-25 in. lbs. (2.26 to 2.82 Nm). Thread the check valve (41) into the 3/8-24 tapped hole into the valve block (11) as shown.

Press the two dowel pins (10) into the holes provided in the bottom of the valve block (11). The pins (10) must be .12" (.3 mm) below the surface.

Place the two sequence seats (8) in the sequence ports (SB, SA). Place the four valve seats (9) in the ports marked RB, RA, RV and servo. Position the gasket (7) and retainer plate (6) over the seats and insert the four screws (4) in the block (11). Torque to 10 in.-lbs. (1.1 Nm).

Position the valve block and the attached parts with four orifices (12) turned up. Insert the two 1-7/16 long springs (17) in the two sequence poppets (13) and install (13) and (17) in the block and over the sequence seats (18) in ports SB and SA. Install the four valve poppets (14) in the ports marked RB, RA, RV and servo. Servo and RV seats to seated with grooved side down. Insert spring retainer (15), large end first, in the servo poppet. Insert the light weight spring (18) 1-9/16" (39.7 mm) long in the RV poppet. Insert the three 1" (25.4 mm) long springs (16) in poppets RB, RA and servo.

Lubricate the two check valves (19) and install in sides of cover (21).

Lubricate O-ring (22) and place on seat (23) and install in valve cover (21). Use a 1/2" 6 point 1/4" drive socket and torque to 15 ft.-lbs. ((20.4 Nm). Do not use impact wrench. Lubricate O-rings (26) and (28) and place on parts (27) and (29). Assemble parts 30, and 33 on (31) and start (31) into housing (29). Push seal piston (27) and O-ring (26) into housing (29) with the small end of the piston exposed. Place spring (25) on cone (24) and insert all these parts in the valve cover (21). Be certain that cone (24) enters seat (23).

Disassemble the strainer assembly (34) and reassemble per the following steps:

- a. Install the orifice screw of the strainer assembly into valve cover. Thread elastic stop nut onto the orifice screw and **torque to 23 lb-in. (2.6 Nm)**.
- b. Install clean filter screen on strainer support and secure in place with socket head cap screw, 6-32 x 1/4" long. **Torque 6-32 screw to 13 lb-in. (1.47 Nm)**.

## ASSEMBLY PROCEDURES

### VALVE BLOCK

before 7-93 (continued)

Lubricate O-rings 37. Install (37) in the block (11).

Position the cover (21) over the springs and poppets and install the four screws (39). **BE CERTAIN THAT THE SPRINGS ARE IN THE RIGHT POSITION BEFORE TIGHTENING THE SCREWS.**

Install dowel pin or roller pin (40) in the hole over the servo poppet. Lubricate the four O-rings (42) and place on the four plugs (43). Install the four plugs. Lubricate O-ring (35) and place on plug (36) and install.

**Caution:** Use of other than SAE plugs will result in malfunction and possible pump damage

Invert the complete assembly and install roll pins (5) thru plate (6) and into the valve block. Install O-rings (2) and (3) in the plate (6).

#### PARTS LIST FOR FIGURE 10

item	description	part no.	qty.
1	not used		
2	O-ring 70-914-2	671-00014	2
3	O-ring 70-914-1	671-00013	2
4	10-24 x 1/2 button hd screw	353-25023	4
5	1/8 x 3/4 roll pin	325-08120	2
6	retainer plate	033-91422	1
7	lower gasket	033-91193	1
8	sequence seat	033-70507	2
9	valve seat	033-70500	4
10	3/16 x 3/4 roll pin	325-12120	2
11	valve block	033-72377	1
12	.047 orifice plug	033-25528	4
13	sequence poppet	033-72378	2
14	valve poppet	033-72379	4
15	spring retainer	033-70482	1
16	spring (1 OAL)	033-71086	3
17	spring (1-7/16 OAL)	033-70512	2
18	spring (light weight)	033-22141	1
19	check valve assy.	S13-40266	2
20	not used		
21	valve cover	033-72376	1
22	O-ring 6290-3	691-00903	1
23	seat	033-70508	1
24	cone	033-12288	1
25	spring	033-12289	1
26	O-ring 70-6227-7	671-00012	1
27	seal piston	033-21767	1
28	O-ring 90-6290-10	691-00910	1
29	housing	033-70545	1
30	5/16-24 hex nut	335-13100	1
31	5/16-24 x 1-1/2 soc set screw	312-13160	1
32	not used		
33	acorn nut	327-25006	1
34	servo strainer assy.	S13-43240	1
35	O-ring 90-6290-6	691-00906	1
36	hex plug SAE-6	488-35003	1
37	O-ring	671-00050	2
38	not used		
39	hex hd cap screw 10-24 x 1-3/4	306-40167	4
40	dowel pin 1/8 x 5/8	324-20810	1
41	pilot relief assy	S23-12813	1
42	O-ring 90-6290-4	691-00904	5
43	hollow hex plug SAE-4	488-35001	5



Valve Block  
(Before 7-93)  
S23-00904

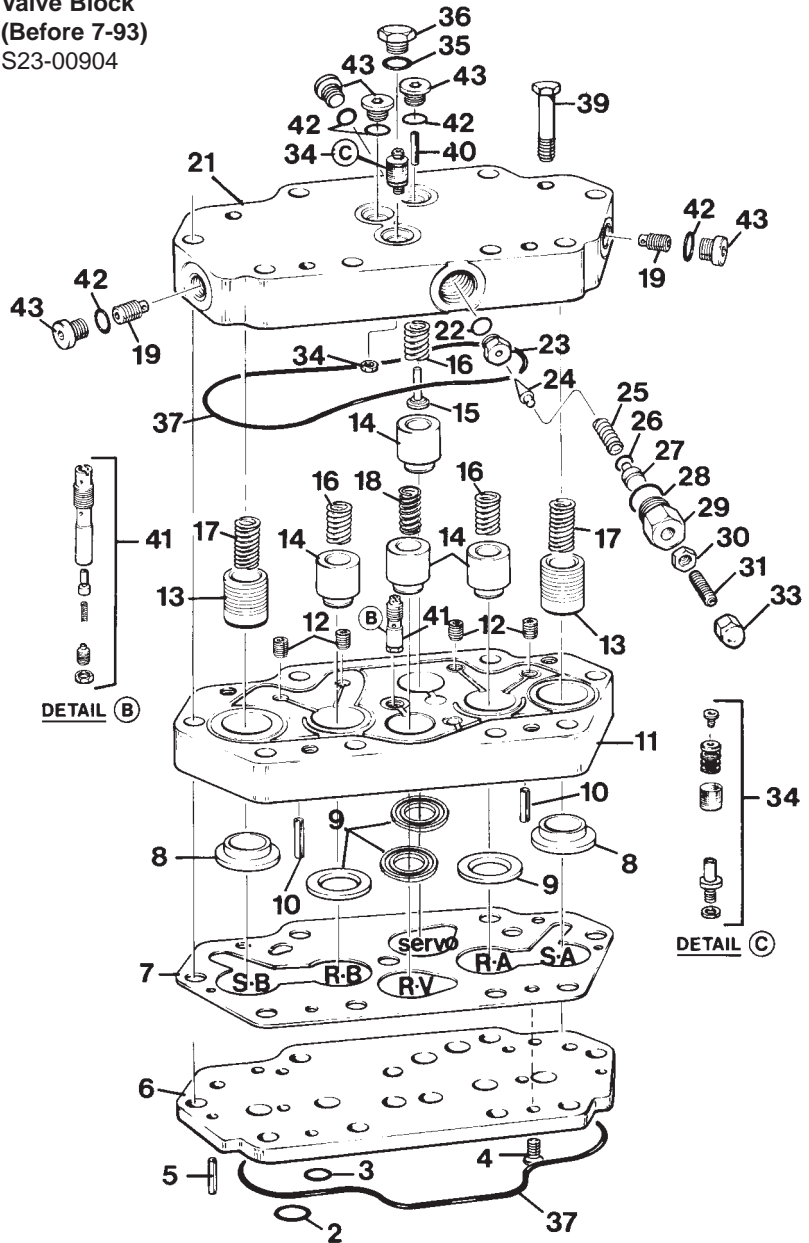

Figure 10

**VALVE BLOCK**  
(after 7-93)

See figure 11.

**Note:** Do not use impact tools or over tighten threaded parts.

Wash and dry all parts. During assembly, lapped and ground surfaces should be kept lubricated with clean oil and protected from nicks or surface damage.

Place valve block (1) with the six poppet valve bores up in order to press two roll pins (46) in position. (Roll pins to be .12" (3.04 mm) below surface of valve block).

Install four orifice plugs (3) into valve block (1) and tighten in place.

Disassemble the strainer assembly (14) and reassemble per the following steps:

a. Install the orifice screw of the strainer assembly into valve block. Thread elastic stop nut onto the orifice screw and **torque to 23 lb-in. (2.6 Nm)**.

b. Install clean filter screen on strainer support and secure in place with socket head cap screw, 6-32 x 1/4" long. **Torque #6-32 screw to 13 lb-in (1.47 Nm)**.

Place valve block with poppet valve bores facing up. Position gasket (29) on valve block.

### VALVE BLOCK

*after 7-93 (continued)*

Place springs (33), 1.43" (36.3 mm) into outer most bores at each end of the valve block. Place sequence poppets (30) over these springs. Position seats (27) small shoulder side first over poppets.

Place springs (35), 1.09" (27.7 mm) into bores next to the sequence poppet valves of step 5. Place dual relief poppet (31) over these springs. Position seats (28) with the groove side facing up, over poppets.

Place spring (32) 1.56" long (39.6 mm) into bore next to compensator valve side of block. Install replenish poppet over spring. Position seat (28) with the groove side facing down, over poppet.

Insert spring (35) 1.09" long (27.7 mm) into the remaining bore. Place spring retainer (34) in spring. Place servo poppet (31) over the retainer and spring. Position seat (28) with the groove side facing down, over poppet.

Carefully position the retainer plate over seats and poppets. Pressing with one hand on the valve block, compress seats, poppets and springs far enough to alternately thread two button head cap screws (43) in far enough to hold the retainer plate. Install the other two screws and alternately tighten screws. Torque to 30 lb-in. (3.39 Nm).

Lubricate O-ring (4) and install on to seat (5), thread seat in valve block. (Be careful not to damage bore in the seat.) Torque to 15 lb-ft (20.34 Nm).

Apply vaseline to shank of cone (13) and install spring (12) on cone. Carefully insert cone and spring into valve block positioning point of cone into bore of seat.

Lubricate O-ring (11) install in groove of piston (10) and insert end into spring (12).

Lubricate O-ring (9) and install on housing guide (8) and thread into valve block. Tighten in place.

Thread nut (7) on socket set screw (6) and thread screw into housing guide (8) until it starts to compress spring.

Using a small bladed screw driver, thread the pilot replenishing relief valve assembly (36) into valve block and lightly tighten in place. (Do not over tighten. Over tightening can cause sides of slot to break now or at next removal.)

Lubricate O-ring (4) and install on plug (25) and tighten plug in place.

Thread check valve (2) into valve block and lightly tighten in place. (Do not over tighten.) Lubricate O-ring (22) and install on plug (23) and tighten in place.

Repeat step 18, on other end of valve block.

Lubricate O-ring (19) and install on plug (20) and tighten plug in place.

Install pin (21). Lubricate O-ring (22) and install over plug (23) and tighten plug in place.

Lubricate O-ring (4) and install on plug (25) and tighten in place.

Lubricate two O-rings (22) and install over two plugs (25) and tighten in place.

Using a small hammer carefully tap roll pins (46) into and thru the retainer plate (42), the pins should bottom out in hole leaving enough length sticking out for piloting into the port block.

Lubricate O-ring (47), (48) and (37) and install in the bottom of retainer plate (42).

Valve is ready to install on pump.



**Valve Block  
(After 7-93)  
S23-12770**

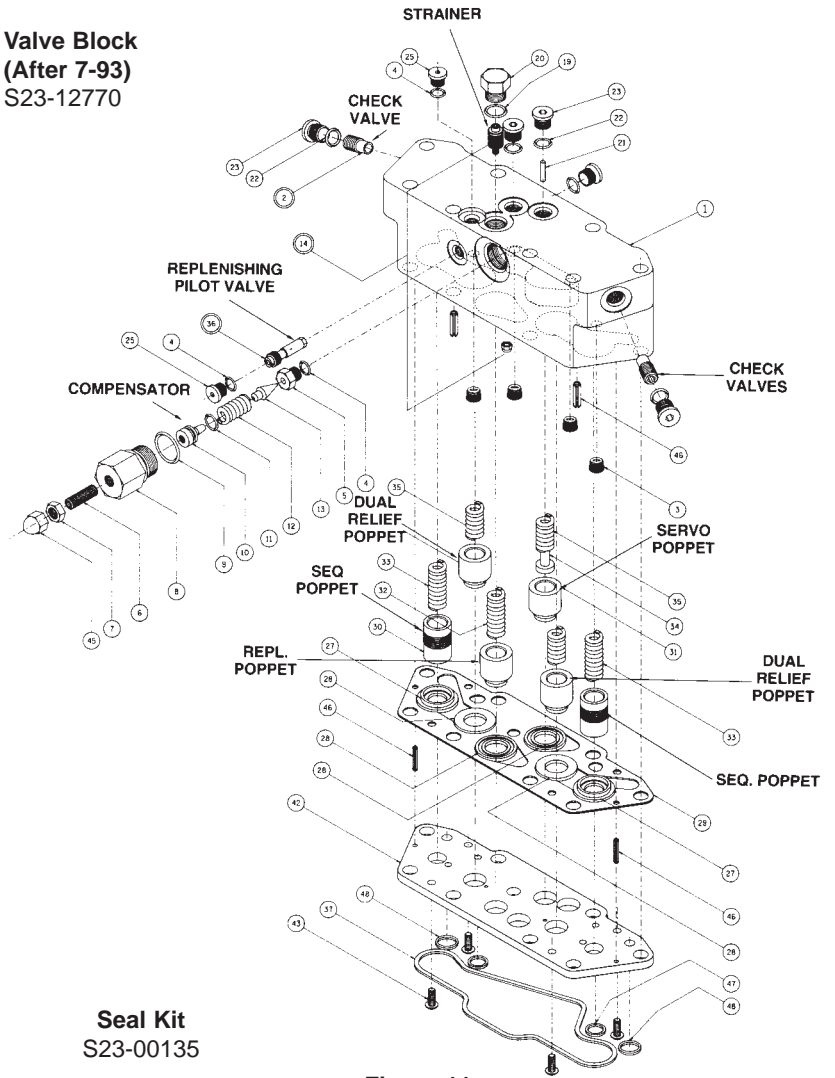

**Seal Kit  
S23-00135**

**Figure 11**

PARTS LIST FOR FIGURE 11

item	description	part no.	qty.
1	valve block	033-91221	1
2	check valve	S13-40266	2
3	orifice plug (.0465 dia.)		
	(1.18 mm)	033-91249	4
4	gasket, O-ring	691-00903	3
5	seat	033-70508	1
6	screw, socket head 5/16-24 x 1	312-13160	1
7	nut, hex jam 5/16-24	335-13100	1
8	housing guide	033-70545	1
9	gasket, O-ring	691-00910	1
10	piston	033-21767	1
11	gasket, O-ring	671-00012	1
12	spring	036-12289	1
13	cone	036-12288	1
14	assy servo strainer	S13-43240	1
19	gasket, O-ring	691-00906	1
20	plug	488-35003	1
21	pin, 1/8 x 5/8	324-20810	1
22	gasket, O-ring	691-00904	5
23	plug	488-35001	5
25	plug	488-35049	2
26	pin, roll 3/16 x 3/4	325-12120	2
27	seat, sequence	033-70507	2
28	replenish & servo seat	033-70500	4
29	gasket, valve block	033-91193	1
30	poppet, sequence	033-72378	2
31	poppet, dual & replenish	033-72379	4
32	spring, replenish	033-22141	1
33	spring, sequence & servo	033-70512	2
34	spring retainer	033-70482	1
35	spring, dual relief	033-71086	3
36	pilot valve, replenish relief	S23-12813	1
37	gasket, O-ring	671-00050	1
42	retainer plate	033-91422	1
43	screw, button head		
	#10-24 x 3/4 LG	353-25078	4
45	nut, acorn 5/16-24	327-25006	1
46	pin, roll 1/8 x 3/4	325-08120	2
47	gasket, O-ring	671-00013	2
48	gasket, O-ring	671-00014	2

**VALVE BLOCK**

for special mounting of servo valve  
(before 7-93)  
S23-11433

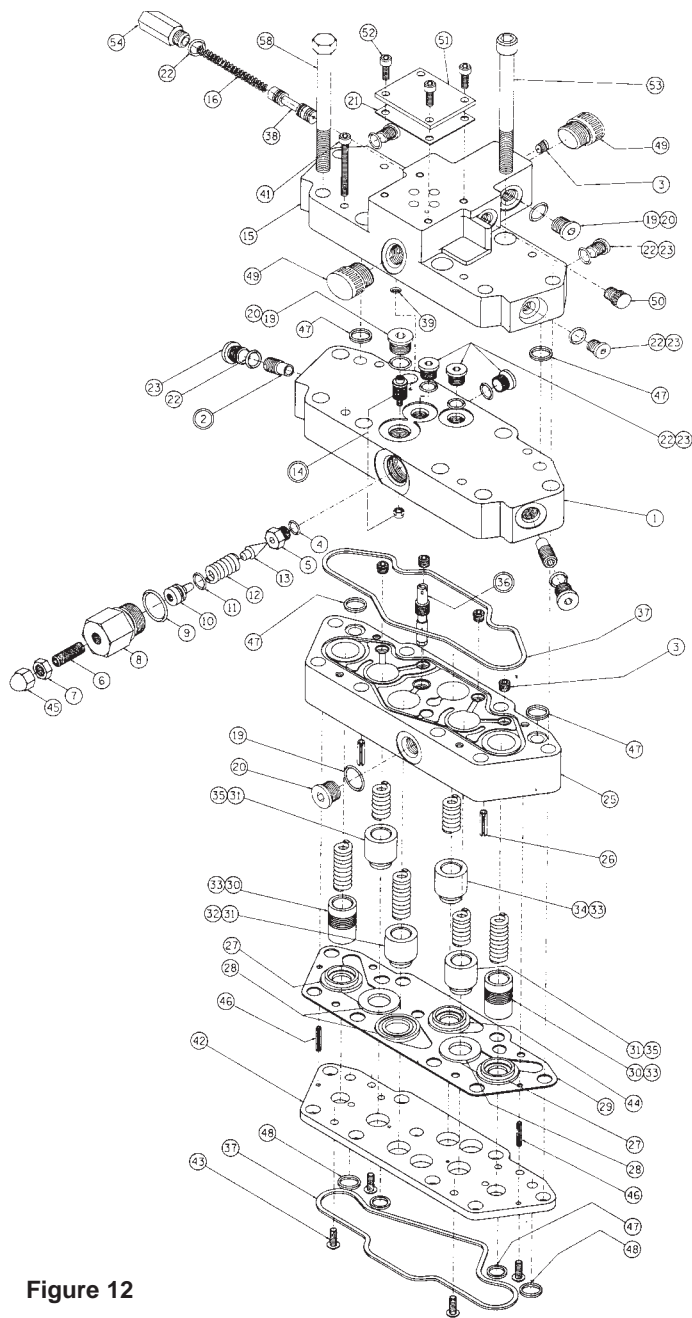

Figure 12

See figure 12.

**Note:** Prior to assembly of reconditioned parts, check finish of gasket surface on valve block and retainer. Must have 60 rms finish with no grinding marks which might carry oil to outside surface. If lapping is necessary, check depth of pockets for valve seats after lapping. Must be .085" (2.16 mm) minimum after lapping, to provide clearance for valve seats.

Wash and dry all parts. During assembly, lapped and ground surfaces should be kept lubricated with clean oil and protected from nicks or surface damage.

Place valve block (25) with O-ring groove down and horizontal in order to press two roll pins (26) in position. (Roll pins need to be .12" (3.05 mm) below surface of valve block).

Apply a liberal amount of vaseline or grease to the six counterbores in the face of the valve block (25). Install two valve seats (27) tapered bore side first, into counterbores and against roll pin (26), one required each end, (outer-most counterbores in block). Insert the valve seats (28) and valve seat (44) in remaining counterbores as shown.

Press two roll pins (46) into retainer plate (42). Each roll pin should stick out approximately .25" (6.35 mm) from each face of the retainer plate.

**VALVE BLOCK**

*for special mounting of servo valve  
before 7-93 (continued)*

Position valve block gasket (29) on valve block. Take care that none of the gasket is covering the valve seats.

- a. Position retainer plate (42) with O-ring grooves facing up, over valve block gasket. Install four button-head cap screws (43), torque to 30 in.-lbs. (3.39 Nm).
- b. Turn the assembly over so that it is resting with the retainer plate O-ring side downward.

Place spring (33) (1.43" long) (36.3 mm) into poppet (30) and insert small hole end first into outer-most bores at each end of the valve block (25).

Insert three poppets (31) and one poppet (34) in remaining bores as shown, small diameter end first.

Slip springs (33) into poppets (34) and (30) as shown.

Insert two springs (35) (1.09" long) (27.7 mm) into remaining outer poppets (31).

Install spring (32) 1.56" long (39.6 mm) into remaining poppet located in center of valve block.

Install four orifice plugs (3) in valve block (25) and tighten in place.

Thread pilot replenishing relief valve (36) into block (25). Valve must not extend below lower surface of retainer plate.

Place O-ring (4) onto seat (5) and install in valve block cover (1). (Be careful not to damage bore in seat.) Torque (5) to 15 ft.-lbs. (20.4 Nm). (Do not use impact wrench).

Lubricate O-ring (11) and insert into groove of seal piston (10) and slip spring (12) onto end of seal piston and press into bore of housing guide (8).

- a. Lubricate O-ring (9) and install on housing guide (8).
- b. Place shank of cone (13) into spring (12).
- c. Align cone with seat in valve cover and thread housing guide into bore and tighten in place.

Thread nut (7) on soc. setscrew (6) and thread into housing guide (8) until it starts to compress spring. Thread acorn nut (45) on soc. setscrew (6).

Coat check valve (2) threads with loctite removable thread locker #242 and thread into end of valve cover (1). (Be sure check valve is properly installed and does not block passages from orifice plug (3). Lubricate O-ring (22) and install on plug (23) and tighten.

Repeat above step at the opposite end of the valve cover (1).

Disassemble the strainer assembly (14) in valve block and reassemble per the following:

- a. Install the orifice screw of strainer assembly (14) into valve cover. Thread elastic stop nut onto the orifice screw and torque to 23 in.-lbs. (2.6 Nm).
- b. Install the strainer support, filter screen and #6-32 x 1/4 lg. screw. Torque #6-32 screw to 13 in.-lbs. (1.47 Nm).

Place O-ring (37) and two (2) O-rings (47) into the grooves on the upper surface of the valve block and secure with vaseline or grease.

Place valve cover (1) over valve block (25) positioning over springs (33), (32) and (35) and secure in place with four (4) socket hd. cap screws (41).

Lubricate O-ring (22) and install on plug (23) and tighten in place.

Lubricate O-ring (19) and install over plug (20) and tighten plug in place.

Lubricate O-rings (47) and install in underside of manifold block (15). Carefully, place manifold block (15) on top of the valve cover (1) making sure the O-rings are correctly seated. Secure with four (4) soc. hd. cap screws (41) by threading into valve block (25).

Insert spring (16) and spool (38) into manifold (15) with the spring guide and spring towards the left side of the manifold (15) when viewing from the top rear.

Install temporary plugs (49) and (50) in 1/2" tube and 1/4" tube ports, front and back and side. Insert O-ring (19) and plug (20) in alternate drain port.

## ASSEMBLY PROCEDURES

### PARTS LIST FOR FIGURE 12

(before 7-93)

item	description	part no.	qty.
1	valve cover	033-54391	1
2	valve check	S13-40266	2
3	orifice #56 (.0465) 1/16 pt	033-25528	5
4	O-ring, 90 S-1 ARP 903	691-00903	1
5	seat	033-70508	1
6	set screw, 5/16-24 x 1 cup pt	312-13160	1
7	hex jam nut	335-13100	1
8	guide-housing	033-70545	1
9	O-ring, 90 S-1 ARP 910	691-00910	1
10	piston	033-21767	1
11	O-ring, 70 S-1 ARP 012	671-00012	1
12	spring	036-12289	1
13	cone	036-12288	1
14	servo strainer	S13-43240	1
15	manifold	033-54389	1
16	spring (Lee #LC-038C-19)	225-92083	1
19	O-ring, 90 S-1 ARP 906	691-00906	3
20	plug 6HP5N- PL	488-35041	3
21	gasket	035-47851	1
22	O-ring, 90 S-1 ARP 904	691-00904	10
23	plug, 4HP5N-S w/o PL	488-35001	9
25	valve block	033-54390	1
26	roll pin 3/16 x 3/4	325-12120	2
27	seat sys relief	033-70507	2
28	servo seat	033-70500	3
29	gasket	033-91193	1
30	poppet	033-72378	2
31	poppet	033-72379	3
32	spring	033-22141	1
33	spring	033-70512	3
34	poppet, servo relief	033-54398	1
35	spring	033-71086	2
36	valve, repl	S23-12699	1
37	O-ring, 70 S-1 ARP 050	671-00050	1
38	spool	033-54392	1
39	O-ring, 90 S-1 ARP 008	691-00008	1
41	screw, soc hd 10-24 x 2-3/4	358-10300	4
42	retainer plate	033-91422	1
43	screw	353-25023	4
44	seat, servo relief	033-54399	1
45	acorn nut	327-25006	1
46	rollpin 1/8 x 3/4	325-08120	2
47	O-ring, 70 S-1 ARP 013	671-00013	6
48	O-ring, 70 S-1 ARP 014	671-00014	2
49	plug 3/4-16	449-00016	2
50	plug 7/16-20	449-00013	1
51	cover, gasket	035-47852	1
52	screw, soc hd 10-32 x 1/2	359-09080	4
53	screw, soc hd 3/8-16 x 4	358-16360	4
54	plug	035-54400	1
55	screw, hex hd	306-40132	4
	seal kit	S23-04226	

**VALVE BLOCK**

for special mounting of servo valve  
(after 7-93)  
S23-12776

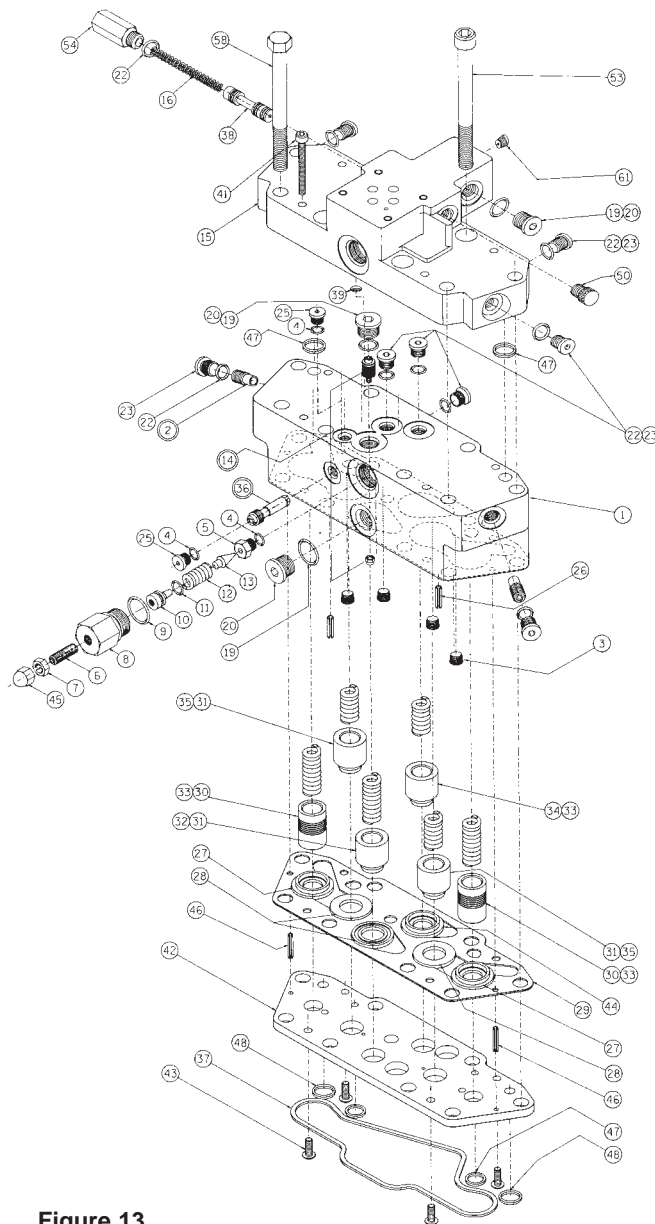

**Figure 13**

See figure 13.

**Note:** Do not use impact tools or over tighten threaded parts.

Wash and dry all parts. During assembly, lapped and ground surfaces should be kept lubricated with clean oil and protected from nicks or surface damage.

Place valve block (1) with the six poppet valve bores up in order to press two roll pins (46) in position. (Roll pins to be .12" (3.04 mm) below surface of valve block).

Install four orifice plugs (3) into valve block (1) and tighten in place.

Disassemble the strainer assembly (14) and reassemble per the following steps:

- a. Install the orifice screw of the strainer assembly into valve block. Thread elastic stop nut onto the orifice screw and **torque to 23 lb-in. (2.6 Nm)**.
- b. Install clean filter screen on strainer support and secure in place with socket head cap screw, 6-32 x 1/4" long. **Torque 6-32 screw to 13 lb-in (1.47 Nm)**.

Place valve block with poppet valve bores facing up. Position gasket (29) on valve block.

Place springs (33), 1.43" (36.3 mm) into outer most bores at each end of the valve block. Place sequence poppets (30) over these springs. Position seats (27) small shoulder side first over poppets.

### VALVE BLOCK

*for special mounting of servo valve  
after 7-93 (continued)*

Place springs (35), 1.09" (27.7 mm) into bores next to the sequence poppet valves of step 5. Place dual relief poppet (31) over these springs. Position seats (28) with the groove side facing up, over poppets.

Place spring (32) 1.56" (39.6 mm) into bore next to com-pensator valve side of block. Install replenish poppet over spring. Position seat (28) with the groove side facing down, over poppet.

Insert spring (33) 1.43" (36.3 mm) into the remaining bore. Place servo poppet (37) over the retainer and spring. Position seat (44) with the tapered bore facing down, over poppet.

Carefully position the retainer plate over seats and poppets. Pressing with one hand on the valve block, compress seats, poppets and springs far enough to alternately thread two button head cap screws (43) in far enough to hold the retainer plate. Install the other two screws and alternately tighten screws. Torque to 30 lb-in. (3.39 Nm).

Lubricate O-ring (4) and install on to seat (5), thread seat in valve block. (Be careful not to damage bore in the seat.) Torque to 15 lb-ft (20.34 Nm).

Apply vaseline to shank of cone (13) and install spring (12) on cone. Carefully insert cone and spring into valve block positioning point of cone into bore of seat.

Lubricate O-ring (11) install in groove of piston (10) and insert end of piston into spring (12). Lubricate O-ring (9) and install on housing guide (8) and thread into valve block. Tighten in place.

Thread nut (7) on socket set screw (6) and thread screw into housing guide (8) until it starts to compress spring.

Using a small bladed screw driver, thread the pilot replenishing relief valve assembly (36) into valve block and lightly tighten in place. (Do not over tighten. Over tightening can cause sides of slot to break now or at next removal.)

Lubricate O-ring (4) install on plug (25) and tighten plug in place.

Thread check valve (2) into valve block and lightly tighten in place. (Do not over tighten.) Lubricate O-ring (22) install on plug (23) and tighten in place.

Repeat above step on other end of valve block.

Lubricate O-ring (19) install on plug (20) and tighten plug in place.

Lubricate O-rings (22) install over plugs (23) and tighten plugs in place.

Lubricate O-rings (4) install on plugs (25) and tighten in place.

Lubricate O-ring (19) install over plug (20) and tighten in place.

Lubricate O-rings (47) and install in underside of manifold block (15). Carefully, place manifold block (15) on top of the valve cover (1) making sure the O-rings are correctly seated. Secure with four (4) soc. hd. cap screws (41) by threading into valve block (25).

Insert spring (16) and spool (38) into manifold (15) with the spring guide and spring towards the left side of the manifold (15) when viewing from the top rear. Install orifice plug (61) in manifold (15).

Install temporary plug, (50) in 1/4" tube port. Insert O-ring (19) and plug (20) in alternate drain port.

Using a small hammer carefully tap roll pins (46) into and thru the retainer plate (42), the pins should bottom out in hole leaving enough length sticking out for piloting into the port block.

Lubricate O-ring (47), (48) and (37) and install in the bottom of retainer plate (42).

Valve is ready to install on pump.

## ASSEMBLY PROCEDURES

### PARTS LIST FOR FIGURE 13

(after 7-93)

item	description	part no.	qty.
1	valve block	033-91335	1
2	valve check	S13-40266	2
3	orifice #56 (.0465)	033-91249	4
4	O-ring, 90 S-1 ARP 903	691-00903	3
5	seat	033-70508	1
6	set screw, 5/16-24 x 1 cup pt.	312-13160	1
7	hex jam nut	335-13100	1
8	guide-housing	033-70545	1
9	O-ring, 90 S-1 ARP 910	691-00910	1
10	piston	033-21767	1
11	O-ring, 70 S-1 ARP 012	671-00012	1
12	spring	036-12289	1
13	cone	036-12288	1
14	servo strainer	S13-43240	1
15	manifold	033-54389	1
16	spring (Lee #LC-038C-19)	225-92083	1
19	O-ring, 90 S-1 ARP 906	691-00906	3
20	plug 6HP5N-PL	488-35041	3
22	O-ring, 90 S-1 ARP 904	691-00904	10
23	plug, 4HP5N-S w/o PL	488-35001	9
25	plug (3HP5N-S)	488-35049	2
26	pin, roll 3/16 x 3/4	325-12120	2
27	seat, sys relief	033-70507	2
28	servo seat	033-70500	3
29	gasket	033-91193	1
30	poppet	033-72378	2
31	poppet	033-72379	3
32	spring, (light weight)	033-22141	1
33	spring (1.47 (36.5 mm) O.A.L.)	033-70512	3
34	poppet, servo relief	033-54398	1
35	spring (1" (25.4 mm) O.A.L.)	033-71086	2
36	valve, repl.	S23-12699	1
37	O-ring, 70 S-1 ARP 050	671-00050	1
38	spool	033-54392	1
39	O-ring, 90 S-1 ARP 008	691-00008	1
41	screw, soc hd 10-24 x 1 1/4	358-10180	4
42	retainer plate	033-91422	1
43	screw	353-25078	4
44	seat, servo relief	033-54399	1
45	acorn nut	327-25006	1
46	roll pin 1/8 x 3/4	325-08120	2
47	O-ring, 70 S-1 ARP 013	671-00013	6
48	O-ring, 70 S-1 ARP 014	671-00014	2
50	plug 7/16-20	449-00013	1
53	screw, soc hd 3/8-16 x 4	358-16360	4
54	plug	035-54400	1
58	screw, hex hd	306-40132	4
61	orifice #56 (.0465)	033-25528	1
	seal kit	S23-04226	



PARTS LIST FOR FIGURE 14

item	description	part no.	qty.
1	no. 3 splined shaft assy. (see fig. 1)	S13-41805	1
	no. 2 keyed shaft assy. (see fig. 1)	S15-41806	
2	shim .008 (.203 mm) (use only 1)	033-53948	1
	shim .007 (.178 mm)	033-53949	
3	ret. ring .066/.068 (1.68/1.73 mm) (use only 1)	033-53901	1
	ret. ring .070/.072 (1.78/1.83 mm)	033-53902	
	ret. ring .074/.076 (1.88/1.93 mm)	033-53903	
4	shaft seal	623-00006	1
5	O-ring	671-00043	1
6	seal retainer	033-57892	1
7	nylrite gasket	631-45003	4
8	screw	306-40144	4
9	servo stem	033-71312	1
10	balance plate	033-70546	1
11	spacer	033-71247	2
12	soc. hd. cap screw 10-24 x 2-3/4	358-10300	2
13	nylrite washer	631-45007	8
14	hex washer hd. screw 3/8-16 x 1-1/4	353-25018	8
15	output control assy.	see below	1
16	input control assy.	see below	1
17	hex. hd. cap screw 3/8-16 x 3-1/4	306-40184	8
*18	O-ring	671-00017	1
*19	O-ring	671-00048	1
20	hex hd screw	306-40025	2
21	optional - gear pump C.W.(see note)	512-42023	1
	- gear pump C.C.W.	512-42024	
	- vane pump TB006 (CW)	024-51095-0/01	
	- vane pump TB006 (CCW)	024-51096-0/01	
22	rear adapter, SAE-A for shuttle valve (Std.)	S23-12362	
	rear adapter, SAE-B for shuttle valve (Std.)	S23-12670	
23	hex screw	306-40224	4
24	shuttle valve-external drain (see fig. 16)	S23-11966	1
	shuttle valve-internal drain (Std.)	S23-12007	

\*Some controls use gasket 033-91058 in lieu of O-rings (cast iron covers). Powder metal covers have groove for O-rings 671-00048, 671-00017.

**Note:** Any pump with SAE-A or SAE-B mounting may be used, with the corresponding adapter assembly (22).

OUTPUT CONTROLS

output controls	part no.
standard, with volume indicator	S13-42064
torque limiter	S23-12299

INPUT CONTROLS

input controls	part no.
10 "B" mtg. CW, "A" mtg. CCW	S23-12327
10 "B" mtg. CCW, "A" mtg. CW	S23-12328
2H	S23-12328
40	S23-12344
4A	S23-12325
4B	S23-12343
4C	S23-12324
5A '0' deadband	S23-12413
5C	S23-12414
60	S13-48944
6B	S23-12424
8A	S23-12268
9A	S23-12667

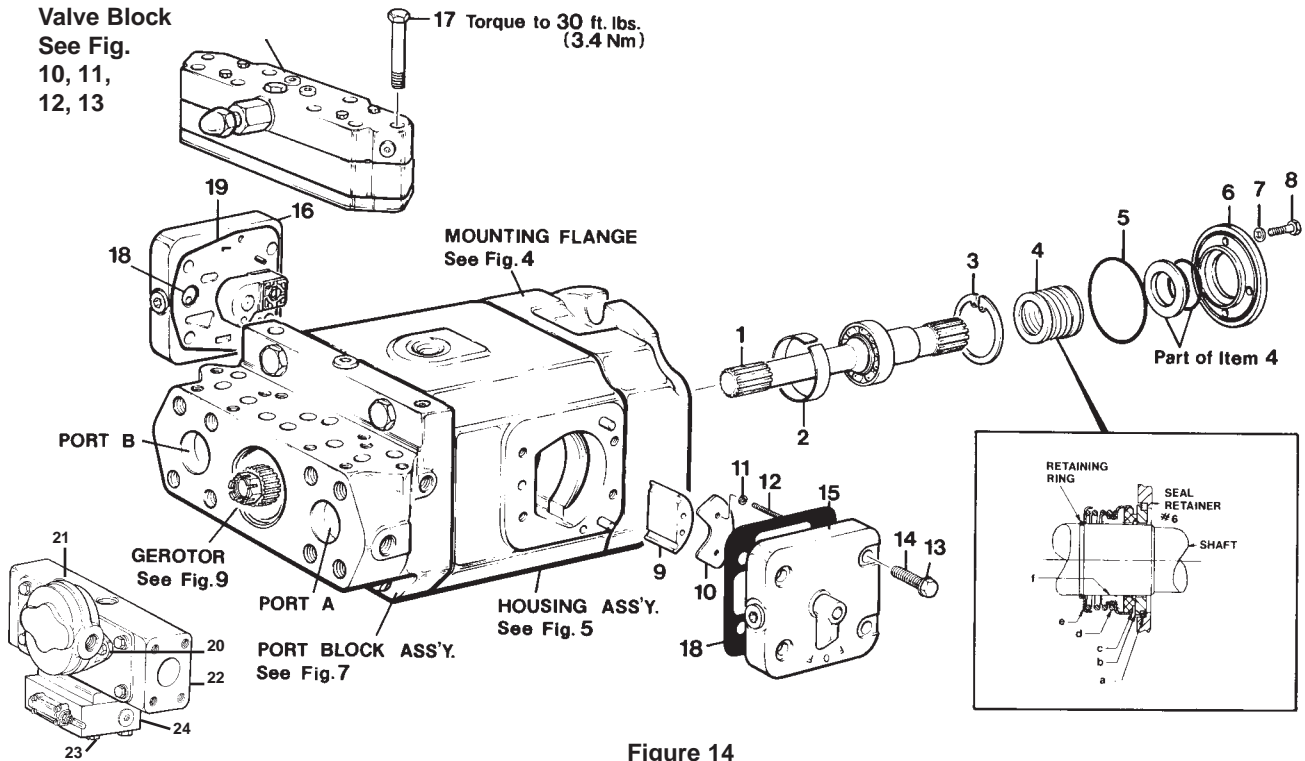

Figure 14

**SHAFT AND SEAL INSTALLATION**

See figure 14. Stand the pump in an upright position with the port block inlet and outlet pads turned down.

Install the shaft and bearing (1) assembly in the mounting flange and cradle. Be certain that there are no burrs or sharp edges on shaft seal area of the shaft.

For a rigid shaft application use the shim (2) that results in least clearance around the shaft bearing. Do not use a shim with a floating shaft.

Install the snap ring (3) in the mounting flange to retain the Shaft Assembly. Be certain that the ring is fully seated in the groove. Use the ring that results in the tightest fit.

**MECHANICAL SHAFT SEAL ASSEMBLY PROCEDURE**

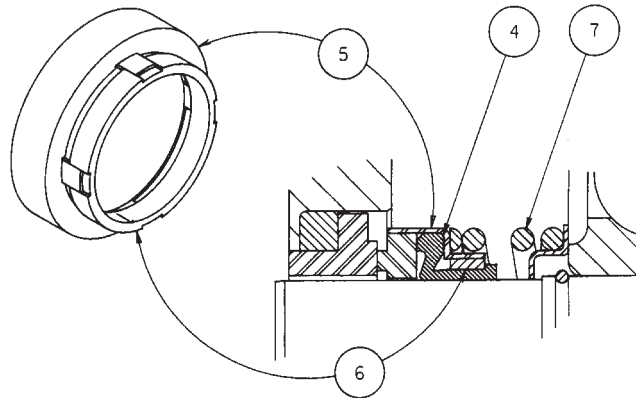

**Warning:** When installing a new mechanical shaft seal, exercise care to insure that all of the parts fit together properly. This is particularly important if the seal was once assembled and disassembled for some reason. If the rubber boot, item 4, grips the shaft and doesn't slide on the shaft, as it is disassembled, then the spring, item 7, can disengage the shell, item 5, from the band, item 6, so that they do not re-engage properly when reassembled. Be sure the shell and the band are properly engaged before reassembling the seal, and stays engaged during assembly.

**Note:** Lubricate seal and shaft with clean hydraulic fluid of the same type that will be used in the system.

See figure 14. The seal assembly (4) is available as a complete unit only.

**Caution:** Before installing the seal assembly examine all the parts. The lapped seal seat and the carbon ring have a precision finish that must be handled with care. Be certain that both parts are free of scratches, marks and cracks.

Place the spring retainer (e) over the shaft and against the retaining ring on the shaft assembly. Place the spring (d) against the retainer (e). Apply grease to the inner surface of the rubber friction ring (f) and position the shell containing the rubber friction ring (f) and carbon ring (c) over the shaft with the carbon ring exposed. Apply grease to the square section rubber seal (a) and install on the ceramic seat (b). Insert the seat and seal in the seal retainer (6) with the lapped side of the seat in position to contact the carbon ring. Place the seal retainer assembly and O-ring (5) over the shaft with the lapped surface against the carbon face. Place the four gaskets (7) on the four screws (8) and insert the seal retainer (6). Depress the seal retainer only far enough to start the four screws and tighten evenly. Torque to 10 ft.-lbs. (13.56 Nm).

**Note:** Seal installation must be completed quickly to avoid the rubber friction ring from seizing on the shaft.

**COUNTER-BALANCE SERVO STEM**

Place the two spacers (11) on the two screws (12) and insert through the balance plate (10) and servo stem (9).

Insert these parts through the opening in the side of the housing assembly and position the screws over the two #10-24 tapped holes in the rocker cam.

Hold these parts against the cam and alternately tighten the screws (12) to hold the assembly firmly in place. Torque screws to 5 ft.-lbs. (6.78 Nm)

**REAR DRIVE ADAPTER**

See figure 15. Place wave spring, (8) over isolation tube (4). Lube O-ring (7) and assemble to isolation tube. Place isolation tube against pressure plate, item (9) Fig. 9.

Lube O-ring (5) and assemble to adapter (1).

Lube tetraseals (10). Insert into adapter block and carefully assemble adapter block to port block. Using screws (9) and washers (12) to hold adapter block in place, torque to 150 ft.-lbs. (203 Nm).

Insert retaining ring (6) into groove of coupling insert (3).

Coupling (2) with coupling insert (3) and retaining ring (6) may be installed to end of auxiliary shaft when external pump is mounted.

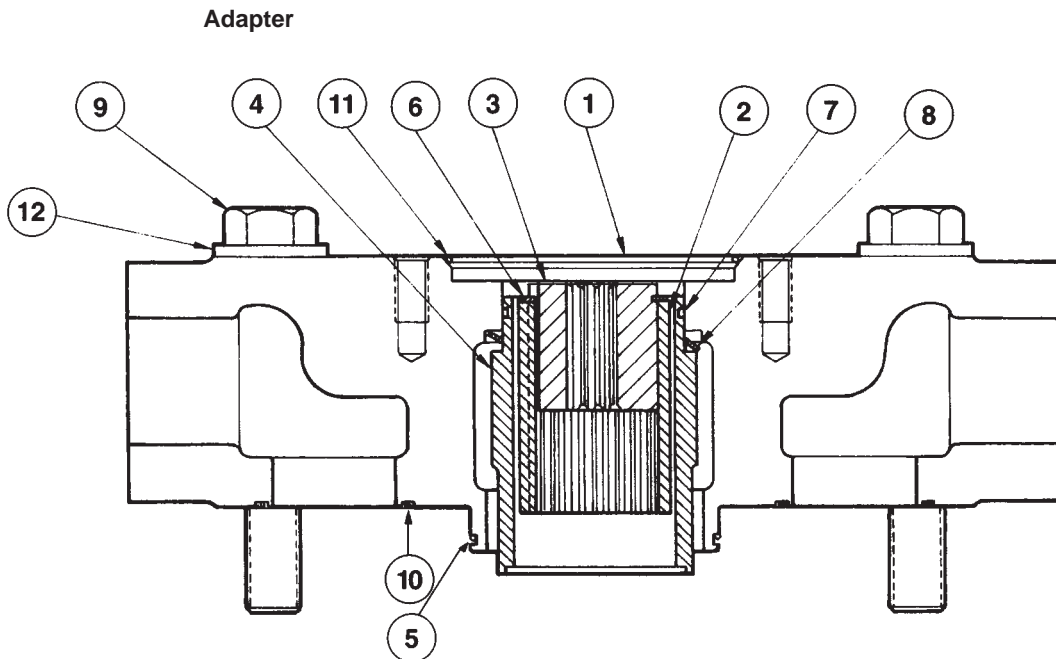

Figure 15

PARTS LIST FOR FIGURE 15

item	description	part no.	qty.
1	adapter — SAE-A with shuttle pad	033-91015	1
	adapter — SAE-B with shuttle pad	033-57967	
	adapter — SAE-A no shuttle	033-57958	
	adapter — SAE B no shuttle	033-57957	
2	coupling	033-57963	1
3	insert — SAE-A	033-57965	1
	insert — SAE-B	033-57964	
4	tube — Isolation	033-57966	1
5	gasket — O-ring	671-00147	1
6	retaining ring	356-65128	1
7	gasket — O-ring	671-00033	1
8	spring — wave	225-92093	1
9	screw — HHC	306-40088	4
10	gasket — Square	691-10131	2
11	gasket — O-ring (with SAE-A)	671-00152	1
	gasket — O-ring (with SAE-B)	671-00155	
12	washer	350-10136	4

PARTS LIST FOR FIGURE 16 SHUTTLE VALVE

item	description	part no.	ext. drain qty.	int. drain qty.
1	blk-shuttle	033-57752	1	1
2	pilot valve ext. drain	S23-22865	1	—
	pilot valve int. drain	S26-22867	—	1
3	spool	033-57180	1	1
4	spring stop washer	033-57182	2	2
5	sleeve	036-27549	1	1
6	piston	036-32902	1	1
7	spring	036-27547	1	1
8	spring	033-57181	2	2
9	O-ring	691-00125	2	2
10	O-ring	691-00026	1	1
11	tetraseal	691-10221	2	2
12	plug	488-35024	2	2
13	screw, HHC 1/2-13 x 3 1/2	306-40224	4	4
14	screw, SHC 3/8-24 x 1 3/4	359-15220	3	3
15	O-ring	691-00916	2	2
16	plug	488-35014	1	1
17	O-ring	691-00912	1	1
	shuttle valve w/external drain	S23-11966		
	shuttle valve w/internal drain	S23-12007		

PARTS LIST FOR FIGURE 16 PILOT VALVE

item	description	part no.	ext. drain qty.	int. drain qty.
2-1	orifice	036-25528	1	1
2-2	O-ring	695-00013	2	2
2-3	cap	036-38910	1	1
2-4	set screw	312-35051	1	1
2-5	spacer	036-27548	1	1
2-6	piston	036-11694	1	1
2-7	block	036-11710	1	1
2-8	seat	036-11692	1	1
2-9	cone	036-12288	1	1
2-10	spring	036-32465	1	1
2-11	spring	036-85514	1	1
2-12	screw SHC 3/8-24 x 1-3/4 (w/hole)	036-36749	1	1
2-13	piston	036-21767	1	1
2-14	O-ring	675-00012	1	1
2-15	plug	036-21765	1	1
2-16	nut hex 5/16-24	333-13001	1	1
2-17	screw S.S. 5/16-24 x 1-5/8	312-13200	1	1
2-18	nut acorn	036-33474	1	1
2-19	plug hex soc. (external drain)	431-90104	1	—
2-20	plug-SAE-4	488-35001	—	1
2-21	O-ring	691-00904	—	1
	seal kit, shuttle valve	523-15089		

Exploded View of Shuttle Valve  
Valve Exploded View of Pilot Valve

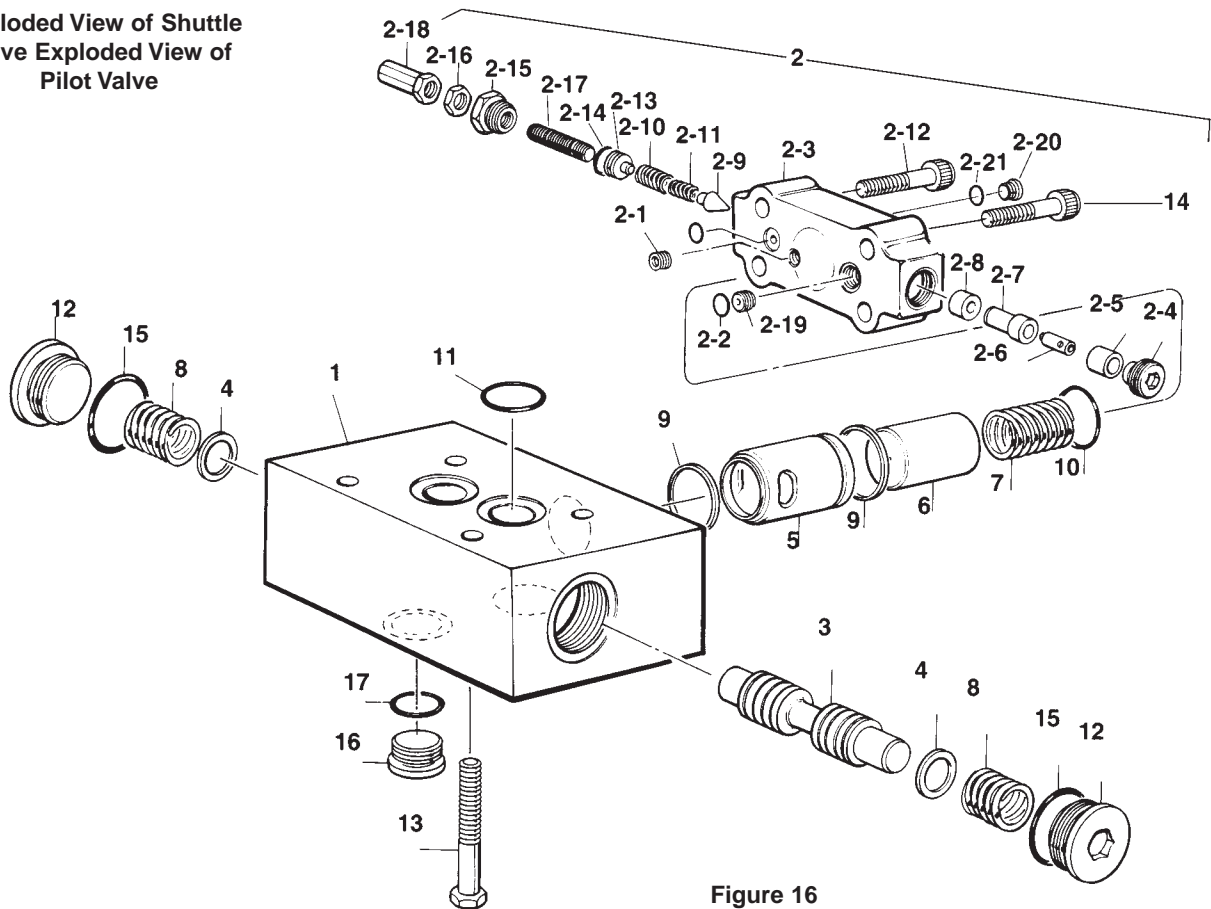

Figure 16

PILOT VALVE

See figure 16. Insert seat (2-8) into cap (2-3) and seat in bottom of bore.

Install small end first of block (2-7) into bore and against seat.

Install small end first of piston (2-6) into block (2-7).

Install spacer (2-5) and secure in place with set screw (2-4).

Install spring (2-11) onto cone (2-9) . Install spring (2-10) over spring (2-11), and insert into cap (2-3) and seat (2-8).

Install O-ring (2-14) in piston (2-13) and insert small end into springs.

Install plug (2-15), screw (2-17) & nut (2-16). Set per requirement and cover with acorn nut. (2-18).

Insert orifice plug (2-1) in center hole of cap.

Grease and install O-rings (2-2).

If externally drained, insert plug (2-19) into hole on spring end of cap.

If internally drained, insert plug (2-20) and O-ring (2-19) in cap drain port.

SHUTTLE VALVE

See figure 16. Lube spool (3) and insert it into valve body (1). When the spool is fully engaged, move the spool back and forth a few times to check for smooth operation. Spool must move freely in body bore.

Install spring stop (4) into one end of valve body (1). Make sure it is seated properly. Insert spring (8) into valve body (1) over the spool (3). Install plug (12) & O-ring (15) into the valve body (1).

Repeat step #2 on other end of valve body.

Lube O-ring (9) and install into valve body (1). Make sure it fits exactly.

Lube O-ring (9) and place over the sleeve (5) and install into bore of valve body (1). Be careful not to jam sleeve in bore.

**SHUTTLE VALVE**

*(continued)*

Insert piston (6) into sleeve (5) and place spring (7) into piston (6).

Lube O-ring (10) and place onto the sleeve (5).

Lube O-rings which come on pilot valve sub-assembly (2).

Mount pilot valve cap sub-assembly (2) onto shuttle block (1). Use three S.H.C. screws (14) and the one screw which comes with the pilot valve sub-assembly. Make sure that the screw that comes with the valve cap sub-assembly is positioned on end closest to acorn nut. Torque to 50 ft-lbs. (68 Nm) Run lead wire which comes with valve cap sub-assembly through holes in special screw and acorn nut. Twist ends together.

**SHUTTLE VALVE MOUNTING**

Lubricate tetraseals (11) figure 16 and place in C' bores of shuttle valve mounting surface.

Carefully attach shuttle valve to adapter (22) fig. 14, using hex hd. screws (13) figure 16. Torque to 75 lb-ft. (102 Nm).

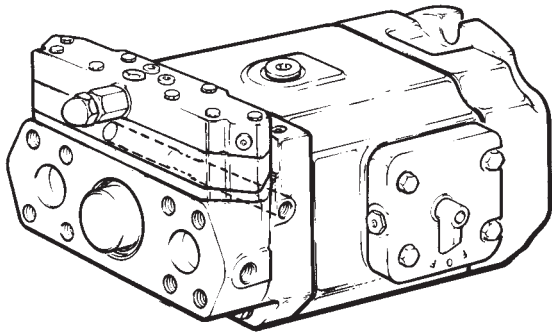

Without Filter No Plug

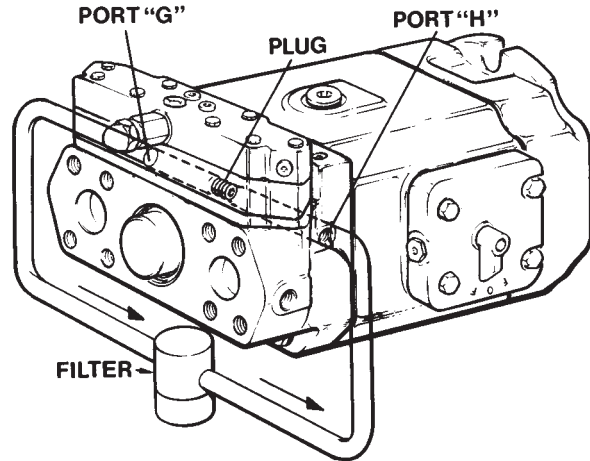

External Filter With Plug

**INSTRUCTIONS FOR  
REPLENISHING CIRCUIT  
ISOLATION PLUG**

**CAUTION:** The isolation plug enclosed is to be used **ONLY** if an external filter circuit is provided. **DO NOT** operate this unit with the isolation plug installed unless an external line has been provided.

When the external filter circuit **IS NOT** used discard the isolation plug.

When the external filter circuit **IS** used install the isolation plug between port G and H (refer to appropriate installation drawing): use a 3/16 Hex. wrench by 4" minimum length **INSERTING THE ISOLATION PLUG INTO PORT H** and tighten to 80 - 120 in.-lb. torque. (9.04-13.56 Nm)

Isolation plug: Part No. 311-45032 (3/8-16 x 1/2 UNC Flat point set screw).







**GENERAL REQUIREMENTS**

1. Maximum runout between pump shaft and electric motor shaft .003 (.076 mm) T.I.R. A floating shaft must have a support in mounting bracket. A fixed shaft should not have a support bearing in mounting bracket.
2. Electric motor speed - 1800 RPM.
3. Inlet temperature - 130° ± 10°F. (54°C ± 4°C)
4. Inlet condition Main Pump 100 to 150 PSI. (6.9 to 10.3 bar)  
Gerotor 10" HG to 5 PSI. (25.4 mm HG to .34 bar)
5. Case pressure 65 PSI ± 10 PSI. (4.5 ± .69 bar).
6. Fluid - 200SSU @ 100°F. (37.8°C)

**BASIC PUMP TEST**

1. Mount pump on test stand. Connect system lines and gerotor inlet line to pump. Connect case drain line to flowmeter. Connect shuttle return line to reservoir. If shuttle pilot valve is externally drained, connect drain to max. 5 PSI (.34 bar) return line. If an auxiliary pump is mounted, connect auxiliary pump inlet to reservoir. If auxiliary pump is not mounted, remove coupling and seal auxiliary unit mounting surface.
2. Start electric motor.
3. Rotate pump input control shaft. The servo control should control pump displacement through its full range. Set pump displacement for full volume, and adjust system pressure for 1000 PSI (69 bar). Check and record system flow and case drain flow above and below center.

	6.0 in <sup>3</sup>	7.25 in <sup>3</sup>	8.0 in <sup>3</sup>
<b>Maximum System Flow</b>	47 GPM (177.9 l/m)	57 GPM (215.7 l/m)	63 GPM (238 l/m)
<b>Maximum Case Drain Flow</b>	1.5 GPM (5.71 l/m)	1.8 GPM (6.8 l/m)	1.5 GPM (5.7 l/m)

4. Back out compensator adjusting screw until unit is fully compensated (count number of turns). Observe volume indicator and stroke rotary servo input shaft from full to full position on each side of center. Indicator should remain on or very near zero position ("O"). If compensator functions normally, return compensator adjusting screw to its original position and proceed with Step 5.

**Caution:** Do not over-tighten adjusting screw.

5. Cycle pump at 10 sec. intervals-full volume above center to full volume below center\*—as follows:  
 5 minutes at 1000 PSI (69 bar)  
 3 minutes at 2500 PSI (172 bar)  
 3 minutes at 3500 PSI (241 bar)  
 2 minutes at 5000 PSI (345 bar)

6. Adjust system pressure to 5000 PSI (345 bar) and set pump displacement for full volume. Check and record system flow and case drain flow above and below center.

\*Pumps with screw adjustment controls do not need to be cycled.

	6.0 in <sup>3</sup>	7.25 in <sup>3</sup>	8.0 in <sup>3</sup>
<b>Minimum System Flow</b>	41 GPM (155.9 l/m)	50.0 GPM (189 l/m)	55 GPM (208 l/m)
<b>Maximum Case Drain Flow</b>	3.0 GPM (11.4 l/m)	3.6 GPM (13.6 l/m)	3.0 GPM (11.4 l/m)

7. Set pump to compensate at 5000 PSI (345 bar). Servo pressure should be at least 650 PSI (45.5 bar). Check and record replenishing flow. (Case leakage flow).

**Maximum flow**-14.6 GPM (55.3 l/m) with Barnes auxiliary pump. 6.5 GPM (24.6 l/m) without auxiliary pump.

8. Set pump to compensate at minimum PSI. Check and record replenishing and servo pressure.

**Servo pressure**-Minus Case Pressure 455 to 570 PSI (31.3 to 39.3 bar).  
**Repl. pressure**-Minus Case Pressure 350 PSI ± 20 PSI (24.1 ± 1.4 bar).

**BASIC PUMP TEST***(continued)*

If pressures are incorrect, remove replenishing relief valve pilot and increase or decrease pressure as required. (One full turn on adj. screw will cause pressure to change approximately 50 PSI) (3.4 bar). Re-torque locknut to 20-25 in-lbs. (2.3-2.8 Nm).

**Note:** There is no servo relief valve adjustment. Increasing or decreasing repl. pressure will cause both servo and repl. pressure to change by the same amount.

9. Set pump to full displacement and set the test stand relief valve at approx. 2000 PSI (138 bar). Set the pump compensator at 1000 PSI (69 bar). Set the shuttle relief valve pilot cap to  $220 \pm 20$  PSI ( $15.2 \pm 1.4$  bar) above case pressure and secure with locknut and acorn nut.

10. Stroke pump to center position and observe repl. pressure. It should rise to the value in step 8 above.

11. Slowly cycle the pump across center several times while observing repl. pressure drops to  $220 \pm 20$  PSI ( $15.2 \pm 1.4$  bar) while on stroke, and rises to  $350 \pm 20$  PSI ( $24.1 \pm 1.4$  bar) at zero stroke, to verify shuttle operation.

12. Set pump to compensate at 5000 PSI (345 bar). Record repl. and servo pressure.

**Servo Pressure**-Minus Case Pressure-660 to 770 PSI (45.5 to 53.1 bar).

**Repl. Pressure**-Minus Case Pressure- $350 \pm 20$  PSI ( $24.1 \pm 1.4$  bar).

13. Set pump to compensate at minimum PSI. Servo pressure should return to 455 to 570 PSI (3.3 to 39.3 bar).

**Note:** After completing step 13, proceed with pump control test and adjustment. Refer to the goldcup control manual #S1-AM030 for your control type. Continue with step 14 after testing controls.

14. Adjust pump displacement for full volume and adjust system pressure to 6000 PSI (413.8 bar). \*\*Adjust compensator from 6000 PSI to 3000 PSI (413.8 to 206.9 bar) to minimum pressure. At each pressure, stroke rotary servo input shaft to the full position on each side of center. Cam indicator should remain on or very near the zero position with no oscillation. System pressure should not vary from Port "A" to Port "B" more than 150 PSI (10.3 bar) and not oscillate.

**Minimum compensator pressure should be under 500 PSI (34.5 bar)**

**\*\*Caution:** DO NOT hold pump at 6000 PSI (413.8 bar) for longer than one minute at any time. This is only an intermittent pressure rating.

15. Set compensator for 1000 PSI (69 bar) when fully compensated, UNLESS OTHERWISE SPECIFIED. Increase and decrease system pressure above and below compensator setting. When system pressure is above compensator setting, the pump should de-stroke and not oscillate. When the system pressure is below the compensator setting, the pump should stroke to full volume.

16. Check pump for external leaks. No external leaks permitted.

**Note:** Refer to Manual S1-AM030 for Control Service information.

**Model number sheet**  
Revised 6/24/02

	P	11	P	-2	R	1	*	-40	2	-B	00	-0	B	0
<b>Gold Cup pumps</b>														
Example model code:														
<b>Pump</b>	P	11	P											
<b>Displacement</b>														
6.00 cu.in./rev. (98 cc/rev.)		6												
7.25 cu.in./rev. (119 cc/rev.)		7												
8.00 cu.in./rev. (131 cc/rev.)		8												
11.0 cu.in./rev. (180 cc/rev.)		11												
14.0 cu.in./rev. (229 cc/rev.)		14												
24.6 cu.in./rev. (403 cc/rev.)		24												
30.6 cu.in./rev. (501 cc/rev.)		30												
<b>Type</b>														
Fixed displacement, closed circuit		F												
Fixed displacement with thru-drive, closed circuit		M												
Variable displacement, closed circuit		P												
Variable displacement with thru-drive, closed circuit		R												
Variable displacement with shuttle package, closed circuit		S												
Variable displacement with thru-drive & shuttle package, closed circuit		L												
Variable displacement, open circuit (for P6, 7, 8, 11, & 14 only)		V												
Variable displacement, open & closed circuit (for P6, 7, & 8 only)		D												
<b>Efficiency</b>														
High efficiency (for P24 only)		H												
Standard efficiency														
<b>Shaft</b>														
Keyed SAE - mechanical shaft seal (single lip seal on P6/7/8F/M)														
Spined SAE - mechanical shaft seal (single lip seal on P6/7/8F/M)														
Keyed SAE-D (mounting & shaft) - mechanical shaft seal (for P6/7/8 only) (single lip seal on P6/7/8F/M)														
Spined SAE-D (mounting & shaft) - mechanical shaft seal (for P6/7/8 only) (single lip seal on P6/7/8F/M)														
Keyed SAE - double lip shaft seal														
Spined SAE - double lip shaft seal														
Keyed (long) SAE - double lip shaft seal														
Keyed (long) SAE - mechanical shaft seal														
<b>Rotation</b>														
Clockwise														
Counter-clockwise														
<b>Seals</b>														
Nitrile (Buna N)		1												
EPR (not available when using "5A" or "5C" primary controls)(pump will be unpainted unless otherwise specified)		4												
Fluorocarbon (Viton)		5												
<b>Design letter</b> (assigned by manufacturer)														
<b>Primary controls</b>														
None (for fixed displacement units only)														
Screw adjustment (spring offset to maximum displacement)														
Cylinder control w/ adjustable maximum volume stops														
Cylinder control - 3 position (spring centered with zero adjustment)														
Cylinder control - 2 position electro-hydraulic w/ adjustable maximum volume stop (spring offset to maximum displacement)														
Cylinder control - 3 position (spring centered) electro-hydraulic														
Rotary servo - spring centered														
Rotary servo - spring centered w/ adjustable maximum volume stops														
Rotary servo - spring centered w/ automatic brake control														
Rotary servo - spring centered w/ adjustable maximum volume stops & automatic brake control														
Electro-hydraulic stroker w/ adjustable maximum volume stops														
Electro-hydraulic stroker w/ adjustable maximum volume stops & automatic brake control														
High IQ with 10 gpm servovalve & 4A (rotary servo) control														
High IQ with 4DC01 valve & volume indicator														
High IQ with 4DC01 valve & 4A (rotary servo) control														
Hydraulic stroker w/ adjustable maximum volume stops														
Hydraulic stroker w/ adjustable maximum volume stops & automatic brake control														
Electro-hydraulic stroker w/ adjustable maximum volume stops														
Electro-hydraulic stroker w/ adjustable maximum volume stops & automatic brake control														
<b>Secondary controls</b>														
None (for fixed displacement units only)														
Volume indicator														
Torque limiter & volume indicator														
Cam position feedback potentiometer														
Cam position feedback RVDT (DC)														
<b>Control location</b>														
None (for fixed displacement units only)														
Primary control on port A side														
Primary control on port B side														
<b>2M* &amp; 2N* controls</b>														
4D01 valve, 110VAC/60Hz with Hirschmann connector														

Model number sheet														
Example model code:														
	P	11	P	-2	R	1	*	-40	Z	-B	00	-0	B	0
<b>Gold Cup pumps</b>														
Revised 6/24/02														
4D01 valve, 12VDC with Hirschmann connector											01			
4D01 valve, 240VAC/50Hz with Hirschmann connector											02			
4D01 valve, 110VAC/60Hz, wiring box											03			
4D01 valve, 12VDC, wiring box											04			
Cetop3 (D03)(NG6) interface, no directional valve											05			
4D01 valve, 24VDC with Hirschmann connector											06			
4D01 valve, 110VAC/50Hz with Hirschmann connector											07			
<b>5** controls</b>														
with deadband											00			
without deadband											01			
<b>7** controls</b>														
without manual override shutoff											00			
with manual override shutoff (required for F, G, J & K primary options)											01			
<b>8** controls</b>														
75 - 350 psi (5 - 24 bar)											00			
75 - 435 psi (5 - 30 bar)											01			
100 - 380 psi (7 - 26 bar)											02			
150 - 400 psi (10 - 28 bar)											03			
75 - 250 psi (5 - 17 bar)											04			
<b>9** controls</b>														
24VDC											00			
12VDC											01			
<b>All other controls</b>														
<b>Reduced displacement options for PF &amp; PM</b>														
Standard cam (19-degree)											00			
P6 with 17-degree cam {5.3 cu.in./rev. (87 cc/rev.)}											10			
P7 with 17-degree cam {6.4 cu.in./rev. (105 cc/rev.)}											10			
P8 with 17-degree cam {7.1 cu.in./rev. (116 cc/rev.)}											10			
P6 with 15-degree cam {4.6 cu.in./rev. (76 cc/rev.)}											20			
P7 with 15-degree cam {5.6 cu.in./rev. (92 cc/rev.)}											20			
P8 with 15-degree cam {6.2 cu.in./rev. (102 cc/rev.)}											20			
P6 with 13-degree cam {4.0 cu.in./rev. (66 cc/rev.)}											30			
P7 with 13-degree cam {4.8 cu.in./rev. (79 cc/rev.)}											30			
P8 with 13-degree cam {5.3 cu.in./rev. (88 cc/rev.)}											30			
P11 with 17-degree cam {9.7 cu.in./rev. (160 cc/rev.)}											10			
P14 with 17-degree cam {12.5 cu.in./rev. (205 cc/rev.)}											10			
P11 with 15-degree cam {8.5 cu.in./rev. (140 cc/rev.)}											20			
P14 with 15-degree cam {10.9 cu.in./rev. (179 cc/rev.)}											20			
P24 with 17-degree cam {22.0 cu.in./rev. (360 cc/rev.)}											10			
P30 with 17-degree cam {27.2 cu.in./rev. (446 cc/rev.)}											10			
<b>Internal pump</b>														
1.07 cu.in./rev. (17.5 cc/rev.) (P6/7/8P/SV/D & P11/14V only)											-0			
2.14 cu.in./rev. (35 cc/rev.) (P11/14P/S only)											-0			
2.81 cu.in./rev. (46 cc/rev.) (P24/30P/S only) (standard)											-0			
1.61 cu.in./rev. (26.4 cc/rev.) (P24/30P/S only) (auxiliary external replenishing flow required)											-1			
1.05 cu.in./rev. (17.2 cc/rev.) (P24/30P/S only) (auxiliary external replenishing flow required)											-2			
3.56 cu.in./rev. (58.3 cc/rev.) (P24/30P/S only)											-3			
4.84 cu.in./rev. (79.3 cc/rev.) (P24/30P/S only)											-4			
5.42 cu.in./rev. (88.8 cc/rev.) (P24/30P/S only)											-5			
6.10 cu.in./rev. (100.0 cc/rev.) (P24/30P/S only)											-6			
No internal pump (standard on P/R/L/F/M)											-X			
<b>External drive</b>														
None														O
Blanking plate (for P6/7/8/11/14S only)														M
SAE-A (SAE 82-2)(P6/7/8/11/14S/R/L/M only)														A
SAE-B (SAE 101-2 for P6/7/8S/R/L/M & P11/14/24/30S)(SAE 101-2 & SAE 101-4 for P11/14/24/30R/L/M)														B
SAE-C (SAE 127-2 for P6/7/8R/L/M & P24/30S)(SAE 127-2 & SAE 127-4 for P11/14/24/30R/L/M)														C
SAE-D (SAE 152-4)(P11/14/24/30R/L/M only)														D
SAE-E (SAE 165-4)(P11/14/24/30R/L/M only)														E
SAE-F (SAE 177-4)(P24/30R/L/M only)														F
<b>External mounting</b>														
No external pump mounted														0
External pump mounted (requires special modification "-M2")(must be separately specified)														1
<b>Special modification</b>														
None														
No paint														omit
Other special modification (example: bronze caged barrel bearing for low viscosity fluids, tandem pumps, etc.)														-NP
														-M2

## AVAILABLE GOLD CUP PUMP CONTROL COMBINATIONS

102	2M2 *00	2N2 *00	402	5A2 *00	7D6 *00	8A2 *00	8C2 *00	9A2 *00
104	2M2 *01	2N2 *01	404	5A2 *01	7D6 *01	8A2 *01	8C2 *01	9A2 *01
106	2M2 *02	2N2 *02	406			8A2 *02	8C2 *02	
107	2M2 *03	2N2 *03	407	5A4 *00	7D7 *00	8A2 *03	8C2 *03	9A4 *00
108	2M2 *04	2N2 *04	408	5A4 *01	7D7 *01	8A2 *04		9A4 *01
	2M2 *05	2N2 *05					8C4 *00	
2A2	2M2 *06	2N2 *06	4A2	5A6 *00	7D8 *00	8A4 *00	8C4 *01	9A6 *00
2A4	2M2 *07	2N2 *07	4A4	5A6 *01	7D8 *01	8A4 *01	8C4 *02	9A6 *01
2A6			4A6			8A4 *02	8C4 *03	
2A7	2M4 *00	2N4 *00	4A7	5A7 *00	7F6 *01	8A4 *03		9A7 *00
2A8	2M4 *01	2N4 *01	4A8	5A7 *01	7F7 *01	8A4 *04	8C6 *00	9A7 *01
	2M4 *02	2N4 *02			7F8 *01		8C6 *01	
2H2	2M4 *03	2N4 *03	4B2	5A8 *00		8A6 *00	8C6 *02	9A8 *00
2H4	2M4 *04	2N4 *04	4B4	5A8 *01	7J6 *00	8A6 *01	8C6 *03	9A8 *01
2H6	2M4 *05	2N4 *05	4B6		7J6 *01	8A6 *02		
2H7	2M4 *06	2N4 *06	4B7	5C2 *00		8A6 *03	8C7 *00	9C2 *00
2H8	2M4 *07	2N4 *07	4B8	5C2 *01	7J7 *00	8A6 *04	8C7 *01	9C2 *01
					7J7 *01		8C7 *02	
	2M6 *00	2N6 *00	4C2	5C4 *00		8A7 *00	8C7 *03	9C4 *00
	2M6 *01	2N6 *01	4C4	5C4 *01	7J8 *00	8A7 *01		9C4 *01
	2M6 *02	2N6 *02	4C6		7J8 *01	8A7 *02	8C8 *00	
	2M6 *03	2N6 *03	4C7	5C6 *00		8A7 *03	8C8 *01	9C6 *00
	2M6 *04	2N6 *04	4C8	5C6 *01	7K6 *01	8A7 *04	8C8 *02	9C6 *01
	2M6 *05	2N6 *05			7K7 *01		8C8 *03	
	2M6 *06	2N6 *06		5C7 *00	7K8 *01	8A8 *00		9C7 *00
	2M6 *07	2N6 *07		5C7 *01		8A8 *01		9C7 *01
						8A8 *02		
	2M7 *00	2N7 *00		5C8 *00		8A8 *03		9C8 *00
	2M7 *01	2N7 *01		5C8 *01		8A8 *04		9C8 *01
	2M7 *02	2N7 *02						
	2M7 *03	2N7 *03						
	2M7 *04	2N7 *04						
	2M7 *05	2N7 *05						
	2M7 *06	2N7 *06						
	2M7 *07	2N7 *07						
	2M8 *00	2N8 *00						
	2M8 *01	2N8 *01						
	2M8 *02	2N8 *02						
	2M8 *03	2N8 *03						
	2M8 *04	2N8 *04						
	2M8 *05	2N8 *05						
	2M8 *06	2N8 *06						
	2M8 *07	2N8 *07						

- Unless otherwise specified on purchase order, the following **Factory setting** will be used.
- Maximum Stop: Full Displacement
- Minimum Stop: Zero Displacement
- Pressure Compensator Override: 1000 nominal psi
- Torque Limiter (\*\*4): P6 @ 1800 rpm = 60 hp nominal
- P7 @ 1800 rpm = 72.5 hp nominal
- P8 @ 1800 rpm = 80 hp nominal



**Denison Hydraulics Inc**

14249 Industrial Parkway  
Marysville, OH 43040 USA  
Tel : ..... 937-644-3915  
Fax : ..... 937-642-3738  
E-mail:  
denison@denisonhydraulics.com

*Call toll-free*  
**800-551-5956**  
*in North America or*  
*visit*  
www.denisonhydraulics.com  
*to locate a*  
**Denison representative**  
*nearest you.*

**North America**

**Canada**

Denison Hydraulics Canada Inc.  
2880 Brighton Road, Unit 1  
Oakville, ON L6H 5S3, Canada  
Tel : +1 (905) 829-5800  
Fax : +1 (905) 829-5805

**Latin America**

**Mexico, Central America, South America, Caribbean countries**

Denison Hydraulics Inc.  
7850 NW 146 Street  
Suite 512  
Miami Lakes, FL 33016, USA  
Tel : +1 (305) 362-2246  
Fax : +1 (305) 362-6220

**Asia-Pacific**

**Australia**

Denison Hydraulics PTY  
41-43 St Hilliers Road  
P.O.Box 192  
Auburn N.S.W. 2144, Australia  
Tel : +61 (2) 9646 5200  
Fax : +61 (2) 9643 1305

**Hong Kong**

Denison Hydraulics Ltd.  
Unit 6A, 33/F Cable TV Tower  
9 Hoi Shing Road, Tsuen Wan  
NT, Hong Kong  
Tel : +852 2498 8381  
Fax : +852 2499 1522

**Japan**

Denison Japan Inc.  
4-2-1 Tsujido-Shinmachi  
Fujisawa 251-0042, Japan  
Tel : +81 (466) 35-3050  
Fax : +81 (466) 35-2019

**People Republic of China**

Shanghai Denison Hydraulics  
Engineering Ltd.  
Room 8018, No. 601  
Zhang Yang Road,  
Pudong New Area  
Shanghai 200120, P.R. China  
Tel : +86 (21) 58205042 / 34  
Fax : +86 (21) 58205014

**Singapore**

Denison Hydraulics PTE LTD  
Blk 4012 Ang Mo Kio Ave 10,  
Unit #07-01D Techplace I  
Singapore 569628  
Tel : +65 268 7840  
Fax : +65 268 7847

**Taiwan**

Denison Hydraulics LTD  
6F-10, No. 79,  
Sec. 2 Roosevelt Rd,  
Taipei, Taiwan, ROC  
Tel : +886-2-23645101  
Fax : +886-2-23639025

**Europe**

**Austria**

Denison Hydraulics GmbH  
Zweigniederlassung Linz  
Haibachstraße 69  
4061 Pasching, Austria  
Tel : +43 (72 29) 48 87  
Fax : +43 (72 29) 6 30 92

**Benelux**

Denison Hydraulics Benelux B.V.  
Pascalstraat 100  
3316 GR Dordrecht, Holland  
Tel : +31 (78) 6543 070  
Fax : +31 (78) 6175 755

**Denmark**

Denison Hydraulics Denmark A/S  
Industrikrogen 2  
2635 Ishøj, Denmark  
Tel : +45 (4371) 15 00  
Fax : +45 (4371) 15 16

**Finland**

Denison Lokomec Oy  
Polunmäenkatu 22  
P.O. Box 116  
33721 Tampere, Finland  
Tel : + 358 (3) 357 5100  
Fax : + 358 (3) 357 5111

**France**

Denison Hydraulics S.A.  
14 route du bois blanc  
BP 539  
18105 Vierzon, France  
Tel : +33 (2) 48 53 01 20  
Fax : +33 (2) 48 75 02 91

**Great Britain**

Denison Hydraulics UK LTD  
Kenmore Road  
Wakefield 41, Industrial Park  
Wakefield, WF2 OXE  
West Yorkshire, England  
Tel : +44 (1924) 826 021  
Fax : +44 (1924) 826 146

**Germany**

Denison Hydraulics GmbH  
Auf dem Sand 14  
D 40721 Hilden, Germany  
Tel : +49 (0) 2103 / 940-3  
Fax : +49 (0) 2103 / 940-558

**Italy**

Denison Hydraulics Srl  
Via Le Europa 68  
20090 Cusago (MI), Italy  
Tel : +39 (02) 90330-1  
Fax : +39 (02) 90390694/5/6  
Denison Calzoni S.p.A  
Via Caduti di Sabbiano15/17  
40011 Anzola dell'Emilia  
Bologna, Italy  
Tel : +39 (051) 6501611  
Fax : +39 (051) 736221

**Spain**

Denison Hydraulics S.A.  
Gomis 1  
08023 Barcelona, Spain  
Tel : +34 (93) 253 1990  
Fax : +34 (93) 211 6507

**Sweden**

Denison Hydraulics Svenska AB  
Sporregatan 13  
213 77 - Malmö, Sweden  
Tel : +46 (40) 600 13 00  
Fax : +46 (40) 600 13 50

**Others**

**Other European, Middle East, African countries**

Denison Hydraulics S.A.  
ATTN: Export Office  
14 route du bois blanc  
BP 538  
18105 Vierzon, France  
Tel : +33 (2) 48 53 01 20  
Fax : +33 (2) 48 53 01 46

For more information, please contact:

**DENISON Hydraulics**

http://www.denisonhydraulics.com