

# DENISON HYDRAULICS

## axial piston variable displacement worldcup series

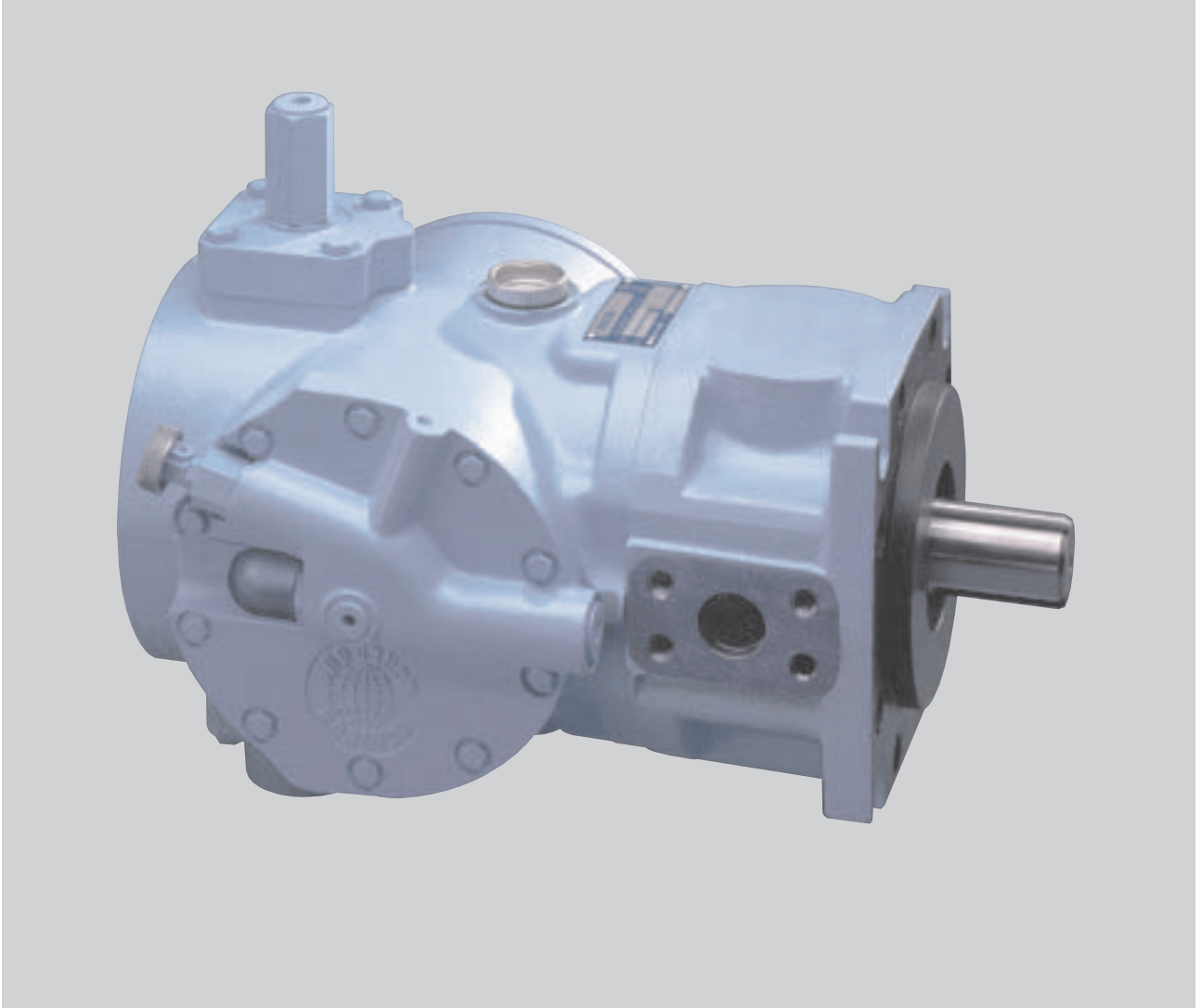

LT1-00059-1 Replaces 1-AM012-C

**DENISON** Hydraulics

E-Mail: [denison@denisonhydraulics.com](mailto:denison@denisonhydraulics.com)  
Internet: <http://www.denisonhydraulics.com>

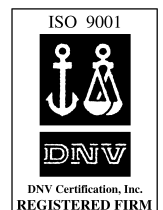

**DATA**

TYPICAL CHARACTERISTICS	Specification	Term	Series 6	Series 7	Series 8
	• displacement (theoretical) zero (bar)	in. <sup>3</sup> /rev. cm <sup>3</sup> /rev	6 (98)	7.25 (119)	8.0 (131)
	• pressure continuous, max.	psi bar	5000 (345)	5000 (345)	<u>3600</u> <u>(250)</u>
	• intermittent max.	psi bar	6000 (414)	6000 (414)	4500 (310)
	• speed, maximum	rev/min	3000	3000	2100
	• at "O" inlet	rev./min	2050	1950	1800
	• case pressure continuous, max.	psi bar	75 (5,17)	75 (5,17)	75 (5,17)
	• intermittent	psi bar	125 (8,6)	125 (8,6)	125 (8,6)
	• compensator adjustment: approx. per turn	psi bar	2000 (138)	2000 (138)	2000 (138)
	• max. volume adjustment, zero to full stroke turns	screw handwheel	10 16	10 16	10 16
	• min. compensator pressure	psi bar	150 (10)	150 (10)	150 (10)
	• max. inlet pressure	psi bar	150 (10,4)	150 (10,4)	150 (10,4)
	• mounting standard, 4 bolt	SAE	152-4 (D)	152-4 (D)	152-4 (D)
	• <u>compensator response*</u>				
	off stroke	sec	0.100	0.100	0.100
	on stroke	sec	0.150	0.150	0.150
	• rotating inertia	lb. in <sup>2</sup> kg. m <sup>2</sup>	92 (0,027)	92 (0,027)	92 (0,027)
	• weight	lbs. kg.	180 (81)	180 (81)	180 (81)
<b>FLUID CONNECTIONS</b>	• port A (inlet) SAE code 61 split flange	in. mm	2-1/2 (62,5)	2-1/2 (62,5)	2-1/2 (62,5)
	• port B (system) SAE code 62 split flange	in. mm	1-1/4 31,25	1-1/4 31,25	1-1/4 31,25
	• port D,D1 (case drain)	SAE	-16	-16	-16
	• port LS (load sensing port)	SAE	-4	-4	-4
	• port V (compensator vent)	SAE	-6	-6	-6
	• port X (rotary servo)	SAE	-6	-6	-6
	• port E, H (rotary servo) (electric & hydraulic stroker inlet)	SAE	-4	-4	-4
	• port RV (cylinder relief port)	SAE	<u>-4</u>	<u>-4</u>	<u>-4</u>

\* For primary compensator control without limiting orifice

**NOTE: New revisions are shown underlined. Pages are marked revised where changes have been made.**

**GENERAL**

The Denison Hydraulics Worldcup 6, 7, and 8 axial piston pumps feature advance design concepts which are time proven and provide for advance pumping and control concepts.

**DESCRIPTION**

The main rotating group is the same as in the Goldcup hydrostatic transmissions that have been in service for more than 24 years.

Standard control for the Worldcup units is a pressure Compensator. Additional optional controls are also available.

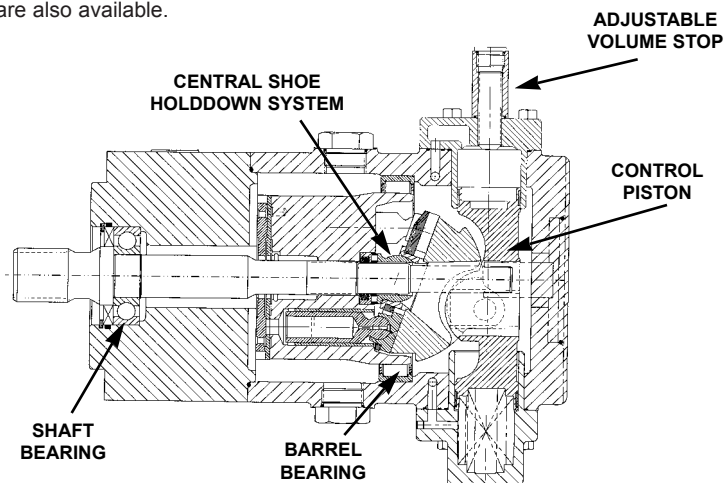

**MOUNTING**

This pump is designed to operate in any position. The mounting hub and four bolt mounting flange are in full conformance with SAE standard. The pump shaft must be in alignment with the shaft of the source driver and should be checked with a dial indicator. The mounting pad or adapter into which the fluid pump pilots must be concentric with the pump shaft to prevent bearing failure. This concentricity is particularly important if the shaft is rigidly connected to the driving load without a flexible coupling.

*Rear Drive*

SAE Size	Coupling* Part No.	Max. Torque In. Lbs.	Rear Seal O-ring ARP
B	031-57170	1852 (209 Nm)	155
BB	031-57171	2987 (338 Nm)	155
C	031-57190	See below	159
D	031-57191	See below	163

\*Coupling mate with SAE splined shafts, flat root side fit, SAE J498B (1971) Class 1.

For C and D rear drives, the maximum torque that may be taken from the rear drive is 9,000 In. Lbs. (1017 Nm), **IF** this does not result in a total torque on the main shaft in excess of 11,000 In. Lbs. (1243 Nm). Example: P7W at 5000 PSI (345 bar) and full displacement requires 5770 In. Lbs. (652 Nm). Thus it can then drive a rear torque load up to 5230 In. Lbs. (590 Nm) maximum. If the P7W will never exceed 500 PSI (577 In. Lbs., 65 Nm) then the maximum rear torque is 9,000 In. Lbs. (1017 Nm).

**Caution:** The shaft and seal area of a rear mounted pump will be exposed to the primary pump's case pressure. This can cause damage to the rear mounted pump's shaft seal. For a rear mounted pump without external drain, modification of the pump's shaft seal will be required if case pressure exceeds that which the rear seal can withstand. If the rear mounted pump contains a case drain, the primary and the rear mounted pump case drains may be connected to a common line to equalize the pressures on the shaft seal.

The product information, specifications, and descriptions contained in this publication have been compiled for the use and convenience of our customers from information furnished by the manufacturer; and we can not, and do not, accept any responsibility for the accuracy or correctness of any description, calculation, specification, or information contained herein. No such description, calculation, specification, or information regarding the products being sold has been made part of the basis of the bargain, nor has same created or amounted to an express warranty that the products would conform thereto. **We are selling the goods and merchandise illustrated and described on this publication on an "as is" basis, and disclaim any implied warranty, including any warranty of merchantability or warranty of fitness for any particular purpose whatsoever, with respect to the goods and merchandise sold.** All manufacturer warranties shall be passed on to our customers, but we shall not be responsible for special, indirect, incidental, or consequential damages resulting from the use of any of the products or information contained or described on this publication. Further, we reserve the right to revise or otherwise make product improvements at any time without notification.

*Shaft options:*

SAE-D splined and keyed, see installation drawing for details.

*Shaft Information*

**Splined:** The shafts will accept a maximum misalignment of 0.006" TIR (0,15 mm). Angular misalignment at the male and female spline axes must be less than  $\pm 0.002$  (0.5 mm) per one inch (25.4mm) radius. The coupling interface must be lubricated. Denison Hydraulics recommends lithium molydisulfide or similar grease. The female coupling should be hardened and must conform to SAE-J498B (1971) Class 1 flat root side fit.

**Keyed:** High strength heat treated keys must be used. Replacement keys must be hardened to 27-34 Rc. The key corners must be chamfered .030"-.040" (.75-1 mm) at 45° to clear radii that exist in the keyway.

*Side Load Capability*

Both types of shafts will accept a side load of 875 lbs. (396 Kg.) at the center of the spline or key, with a B10 life of 10,000 hours at 1800 RPM.

*Piping*

Connect inlet and outlet lines to the port block of the pump. The fluid connections are  
 Inlet: 2-1/2" (62.5 mm), 3000 PSI (207 bar), SAE 4 bolt flange, Code 61  
 Outlet: 1-1/4" (31.25 mm), 6000 PSI (414 bar), SAE 4 bolt flange, Code 62  
 Other: SAE straight thread, O-ring seal.

See installation drawing for size.

The maximum case pressure is 75 PSI(5,17 bar) continuous, 125 PSI (8.6 bar) intermittent. Case pressures must never exceed inlet pressure by more than 25 PSI (1,7 bar). When connecting case drain line make certain that drain plumbing passes above highest point of the pump before passing to the reservoir. If not, install a 5 PSI (0,3 bar) case pressure check valve to be certain the case is filled with oil at all times.

The case leakage line must be of sufficient size to prevent back pressure in excess of 75 PSI (5.7 bar) and returned to the reservoir below the surface of the oil as far from supply suction as possible. All fluid lines, whether pipe, tubing, or hose must be adequate size and strength to assure free flow through the pump. An undersize inlet line will prevent the pump from reaching full speed and torque. An undersized outlet line will create back pressure and cause improper outlet operation. Flexible hose lines are recommended. If rigid piping is used, the workmanship must be accurate to eliminate strain on the pump port block or to the fluid connections. Sharp bends in the lines must be eliminated wherever possible. All system piping must be cleaned with solvent or equivalent before installing pump. Make sure the entire hydraulic system is free of dirt, lint, scale, or other foreign material.

**Caution:** Do not use galvanized pipe. Galvanized coating can flake off with continued use.

**SERVICE INFORMATION**

These hydraulic products are designed to give long dependable service when properly applied and their systems properly maintained. These general instructions apply to typical systems. Specific instructions for particular equipment can be developed from them. Refer to bulletin S1-AM012.

### **RECOMMENDED FLUIDS**

See DENISON Hydraulics bulletin SPO-AM305 for more information.

### **MAINTENANCE**

This pump is self-lubricating and preventative maintenance is limited to keeping system fluid clean by changing filters frequently. Keep all fittings and screws tight. Do not operate at pressures and speeds in excess of the recommended limit. If the pump does not operate properly, check the Trouble Shooting Chart before attempting to overhaul the unit. Overhauling may be accomplished by referring to the Disassembly, Rework of Wear Parts and Assembly Procedures in service manual S1-AM012.

### **FLUID CLEANLINESS**

Fluid must be cleaned before and continuously during operation by filters that maintain a cleanliness level of NAS 1638 Class 8. This approximately corresponds to ISO 17/14.

## PRIMARY CONTROLS

*Compensator Control—  
Code C*

The compensator control is located in the cover assembly, it consists of a compensator spool and a pilot-head. It is redesigned for "Low Flow."

The stroking cylinder is connected to the output port of the compensator spool. The compensator pressure port is internally connected to the discharge port of the pump and the tank port is internally connected to the case drain. The compensator pressure is set at the pilot-head by an adjustment spring.

When the pump operating pressure is below the compensator setting, springs push the stroking piston and the hanger to full stroke. The stroking cylinder is connected to the case drain via the compensator spool.

When the pump operating pressure reaches the compensator pressure setting, the pilot-head opens and a pressure drop is created over the orifice, causing the compensator spool to move against the spring force, directing pump discharge pressure to the stroking cylinder. The pump will destroke to maintain set pressure.

When the pump operating pressure decreases below the compensator setting, the pilot head will close and the compensator spool will move under spring force to its offset position, connecting the stroking cylinder to case. The springs will move the stroking piston to full displacement again.

The compensator can be remotely controlled via the vent connection, which also allows for a load sensing circuit. Minimum compensating pressure or vented pressure is approximately 150 psi (10,3 bar).

Note: Use a 0.040 (1mm) orifice in vent line to prevent flooding the compensator during sensing mode.

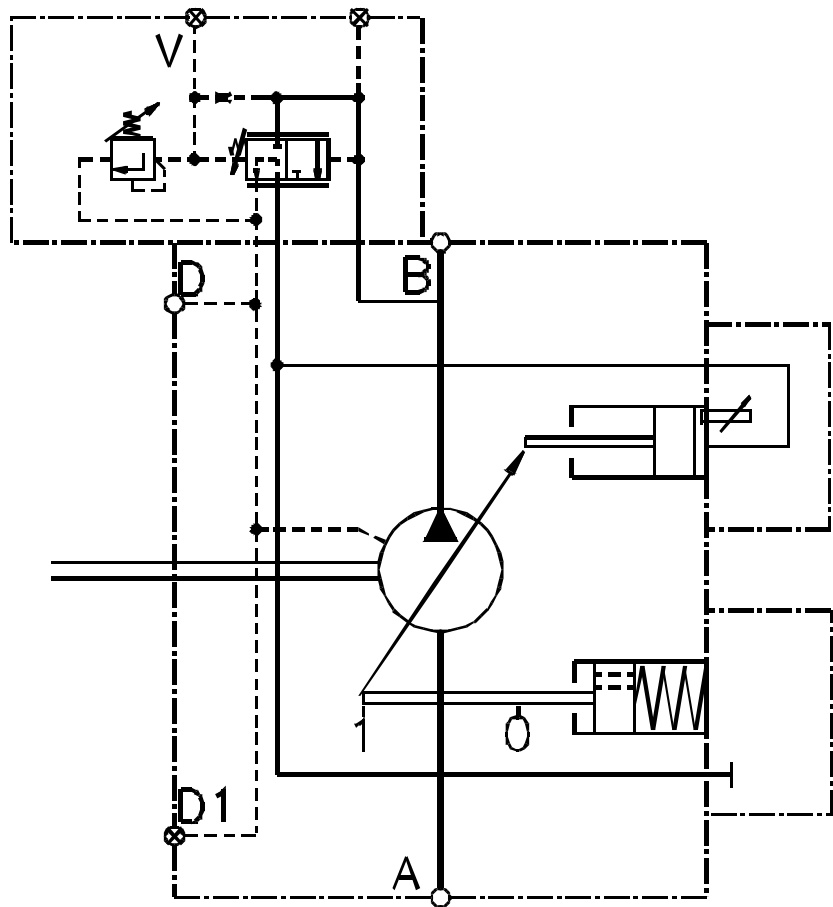

C10

Rotary Servo Control—  
Code R

The rotary servo control consists of a four-port rotary servo which directs servo pressure from an external source to the top stroking cylinder or the bottom stroking cylinder. It requires 1 GPM (4 L/min) servo flow at a pressure of 300 psi (21 bar). Normal recommended servo pressure of 300 psi (21 bar) with a maximum pressure of 1000 psi (70 bar). Response can be increased by adding more flow under higher pressure.

The servo shaft takes a torque of 5-10 lbs-in (0.5-1 Nm) to rotate at 300 psi (21 bar) servo pressure. If we turn the rotary servo shaft counterclockwise, servo pressure port "A" is connected with the top cylinder port "B" and the bottom cylinder port "C" is connected with drain port "D". This means the stroking piston will move down, causing the hanger to turn counterclockwise, reducing the displacement. The rotary servo moves "zero to "full" angle approximately 38 degrees.

As it moves the hanger will move the rotary servo sleeve counterclockwise until the servo pressure port "A" is closed again by the rotary servo shaft, thus cancelling the input signal after the commanded angle has been followed-up by the stroking mechanism.

**Note:** this control requires a minimum servo pressure of 300 psi (21 bar) above case pressure. This must be supplied by the customer or via a rear driven pump.

Stroke Speed Table

Pressure		Stroke	
Servo	System	On	Off
300 psi (21 bar)	500 psi (34.5 bar)	1.0 Second	0.60 Second
300 psi (21 bar)	5000 psi (345 bar)	0.6 Second	0.86 Second

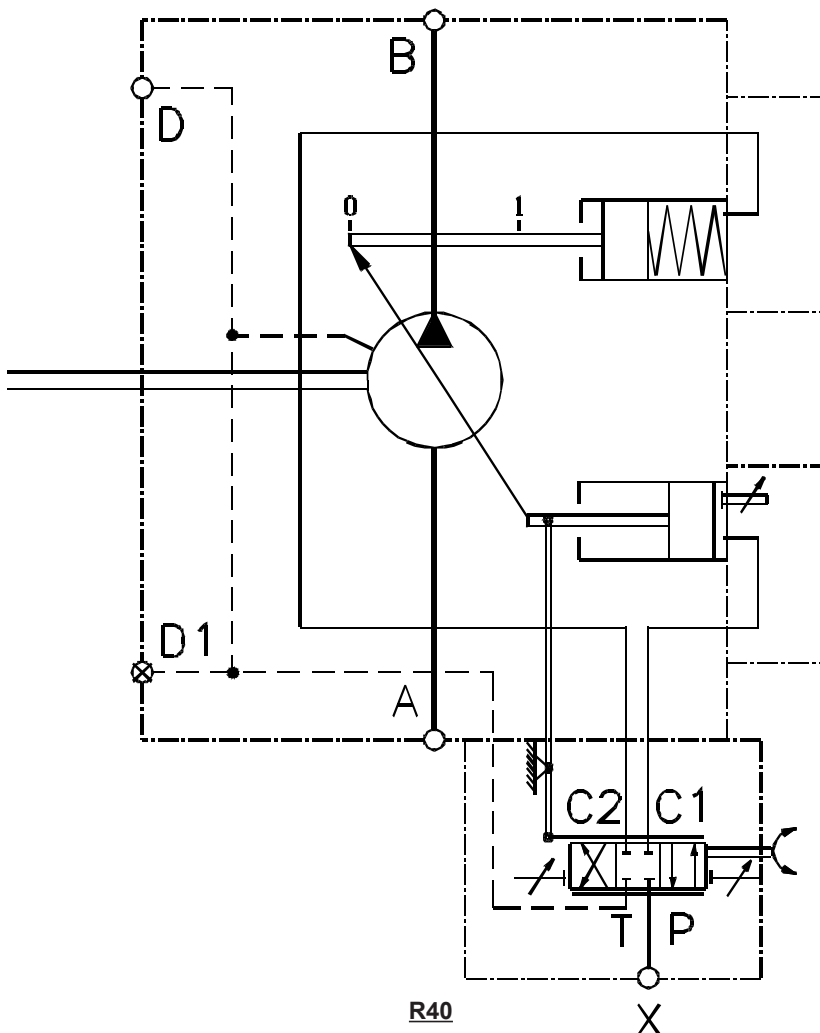

*Electrohydraulic Stroker Control—  
Code E*

This electrohydraulic control actuates the rotary input shaft by means of a hydraulic position. In the zero current condition the jet pipe is centered over the two receiver orifices and generates equal pressure in each receiver. The jet pipe is held in this position by the feedback spring from the piston and the null adjust spring which counter each other and result in a net force of zero on the jet pipe. Assume the current is increased in a polarity that causes the jet pipe to move to the right. This will cause the pressure to increase on the right receiver and fall in the left receiver. Since these pressures are communicated to opposite ends of the piston it will move and in turn move the rotary servo through the arm connecting the piston and rotary servo shaft. The feedback spring is also connected to the arm which continues to move until the force balance re-centers the jet pipe. Thus a new steady state condition is achieved. The control shaft can be manually operated without servo pressure applied to the jet pipe. Spring centering is also available to center the pump when servo pressure is removed from the servo control. **Note: The electrohydraulic control cannot be used if water glycol, phosphate ester, or invert emulsions fluids is used in the system. Note:** This control requires a minimum servo pressure of 300 psi (21 bar) above case pressure. **This must be supplied by the customer or via a rear drive pump.**

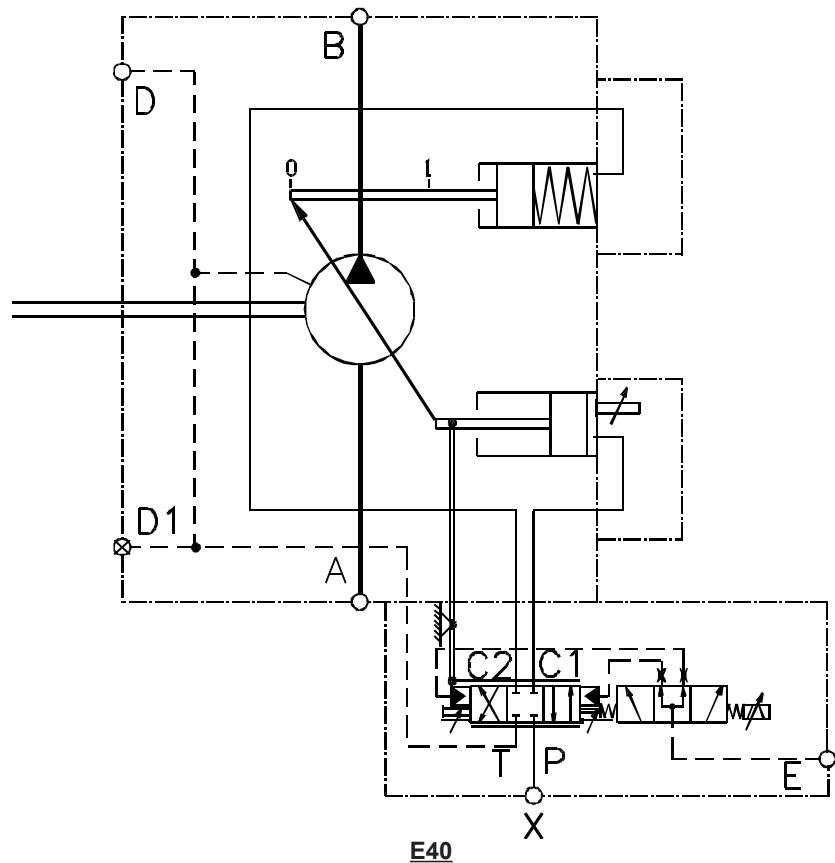

**Hysteresis:** Less than 5%.

**Linearity:** Within 5%.

**Response:** 0.5 seconds from zero to full displacement.

**Threshold:** Less than 2% outside dead band.

**Repeatability:** Within 2%.

**Temperature Null Shift:** Less than 2% per 100°F(38°C).

**Pressure Null Shift:** Less than 2% per 500 psi (35 bar).

**Neutral Deadband:** 0% or 10% of full current.

**Pressure Input:** Externally supplied by customer to servo inlet port from any source



with 400 psi (28 bar) nominal pressure. Pressure range acceptable is 200 to 1000 psi (14 to 70 bar) above pump case pressure.

**Coil Resistance:** 24 to 30 ohm.

**Electrical Input:** 275 mA typical to stroke pump over full 19° cam angle, 400 mA maximum. Current source should have at least a 12V DC capability. Absolute maximum current should be limited to 600 mA to avoid damage to coil. Adjustable displacement stops are provided to mechanically limit the stroke to less than maximum.

**Note:** Control pressure for this control must be provided by the customer or via a rear driven control pump.

**Fluid Type:** Any fluid compatible with the seals and pump may be used.

SEE\* BELOW

See Denison Hydraulics bulletin SPO-AM305 for fluid recommendations.

**Fluid Cleanliness:** This control is capable of passing particles up to 200 Micron in size. It contains a 75 Micron "last chance" filter screen built into the body. See page 5 for cleanliness specifications.

**Jupiter Controls:** (used to control the "E" Stroker)

Driver card—S20-11712

Options card—S20-11716

Power supply—S20-11715

Euro card holder—701-00007-8

**Comments:** The control may be manually overridden only if the external pressure source is disconnected or shut off. A torque of approximately 20 lbs-in (2.3 Nm) is required to rotate the shaft with external pressure disconnected. Do not exceed 100 lbs-in (11 Nm). Adjustable max. volume stops are included and may be adjusted from 0—19°.

**Note:** If the Driver uses Pulse Width Modulation (PWM) the frequency must be 2000 Hz or higher.

**\*Water glycol, Phosphate Ester, or Invert emulsions including "Skydrol" are fluids that cannot be used with electrohydraulic control.**

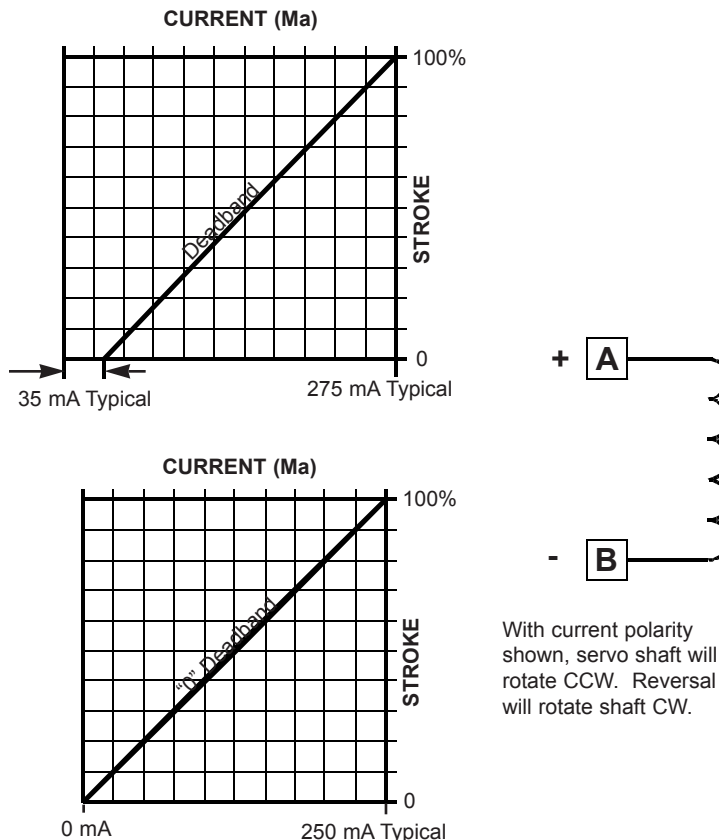

With current polarity shown, servo shaft will rotate CCW. Reversal will rotate shaft CW.

Hydraulic Stroker Control—  
Code H

This control actuates the rotary input shaft by means of a hydraulic piston, which is pressurized by an external pressure source. The piston is biased with a spring, which provides zero displacement. When the external pressure is introduced into one of the control ports, the piston exerts a force on the springs. When this force exceeds the precompression force of the spring, the piston begins to move, rotating the rotary servo shaft in proportion to pressure. Removing or reducing the input pressure allows the spring to move the servo shaft back toward the zero displacement position.

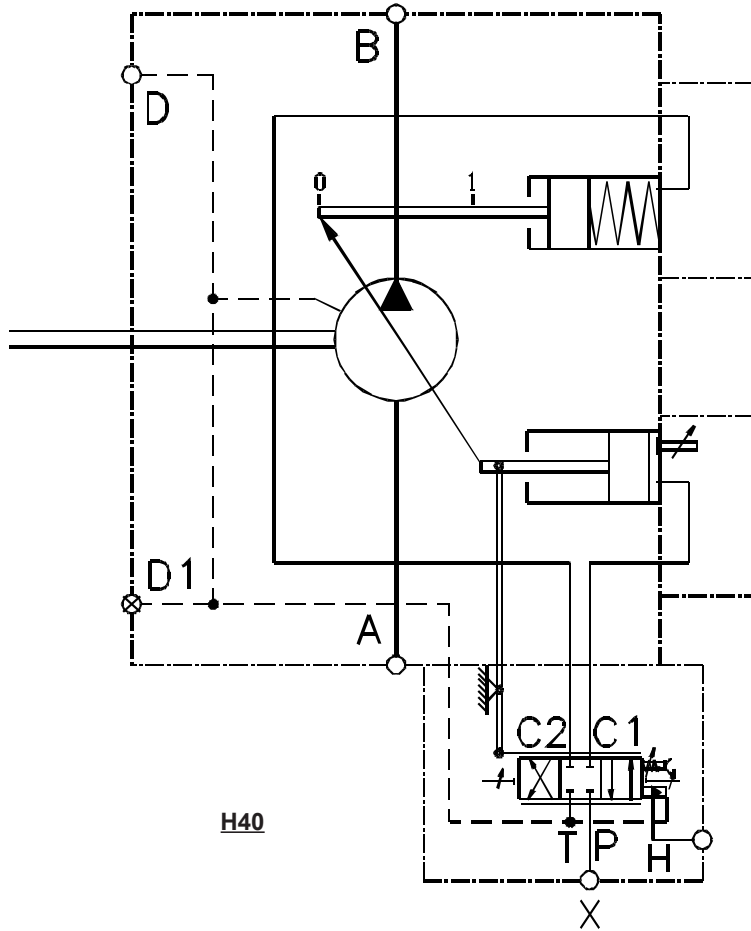

**Hysteresis:** Less than 3%

**Linearity:** Within 2%

**Pressure Input:** Control pressure may be from any suitable external source.

**Comments:** The control may be manually overridden if the external pressure source is disconnected. Do not exceed 100 lbs-in (11Nm) torque on servo shaft in manual mode. Adjustable max. volume stops are included.

**Note:** Control pressure for this control must be provided by the customer or via a rear driven control pump.

**Fluid type:** Any fluid compatible with the seals and pump may be used. see Denison Hydraulics bulletin SPO-AM035 for fluid recommendations.

**Fluid Cleanliness:** See page 5

**Stroke vs Control Pressure**

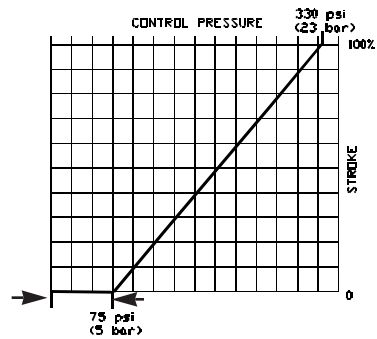

(Other pressure ranges available)

## Load Sensing Compensator Code L

The compensator has a separate load sensing port with an isolation valve between the spool and the load sense port, so that the load sense port sees zero flow. The vent port is still available and can be used for remote control purposes. When used as a load sense compensator, the added valve bypasses the flow from the spool to the case of the pump, rather than allowing it to pass out the load sense port. In this way, the external load sensing valves see no flow and there is no associated pressure drop, so they become a pure pressure control.

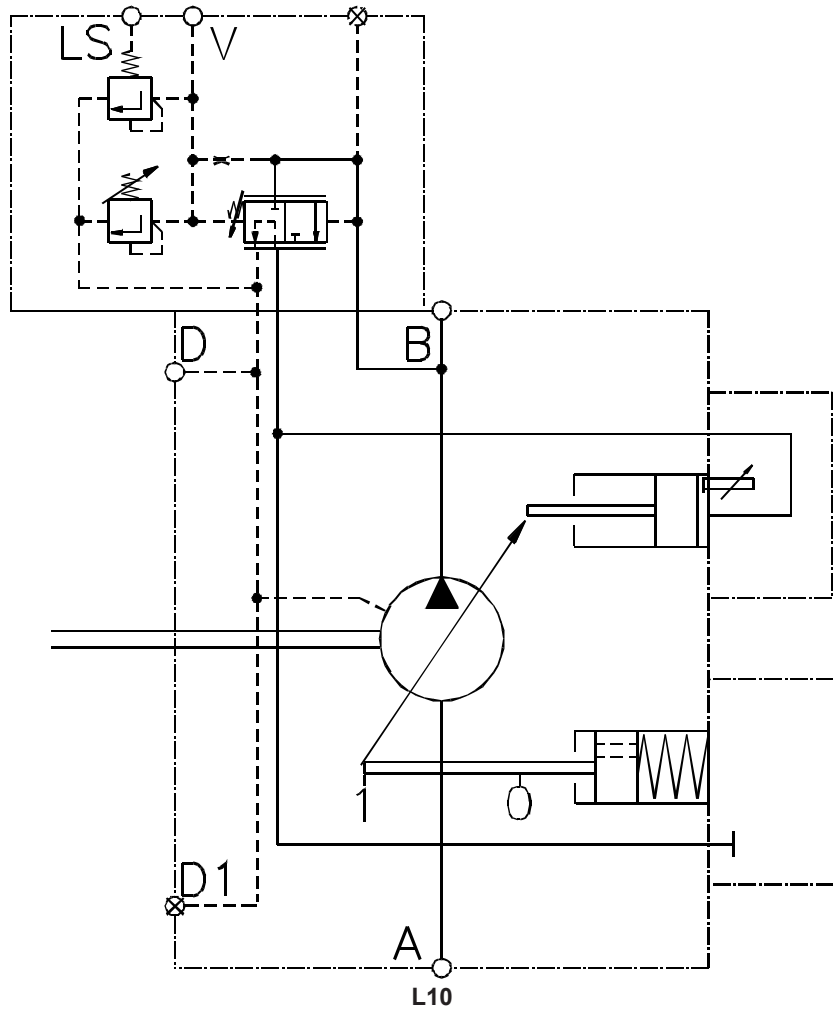

*Torque Limiter—  
Code T*

This control is a combined compensator and torque limiter, or, if used as an override, it is a combined compensator override and torque limiter override. The torque limiter control valve is mechanically driven by the pump rocker cam to provide the proper pressure vs. flow relationship to give constant torque. This valve operates in parallel with the standard compensator valve and controls the displacement of the pump through the compensator as a function of pressure.

The torque limiter control used as the primary control on the pump provides both pressure compensator functions and torque limiting functions.

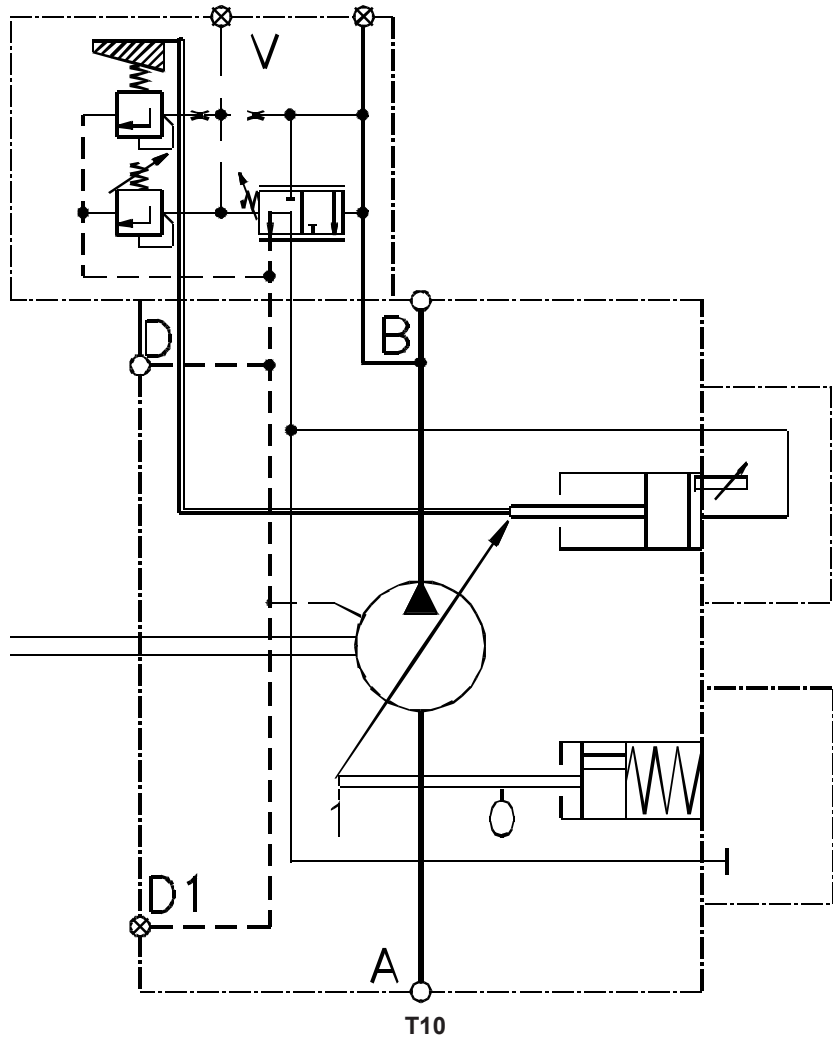

**PRIMARY CONTROL OPTIONS**

*Maximum Volume Screw Control—  
Code 1*

Screw control is similar in action to the handwheel control described in the following paragraph where-in the adjustment is made by raising or lowering the maximum volume stops to regulate pump delivery.

*Maximum Volume Handwheel Control  
Code 2*

This control provides a means of manually setting the maximum volume delivered by the pump. Setting is made by use of the the handwheel which positions the cam plate in the desired position.

*Maximum and Minimum Volume  
Stops for the Control Codes "R",  
"H", and "E" Only—  
Code 4*

The maximum and minimum stops limit the angle of the rotary servo shaft, replacing the Code 1 or Code 2 stops. These stops are fully adjustable and are located in the control cover assembly.

**SECONDARY CONTROL OPTIONS**

*Pressure Compensator Override—  
Code P*

The pressure compensator override is an optional control, used when needed with the rotary, electrohydraulic or hydraulic servo strokeers.

In this control the stroking cylinder is spring offset to the zero position. It has the same rotary servo described previously, but in addition, a cover assembly containing the compensator override on the opposite side of the pump. The compensator override control is similar to the compensator control as described before, except the override path to the top stroking cylinder is provided with a check valve and orifice to limit the losses from the top stroking cylinder. The bottom stroking cylinder is interconnected to the rotary servo port "C" but plugged-off from the compensator override.

If the pump operating pressure reaches the compensator pressure setting, discharge pressure is directed to the top stroking cylinder. This causes the stroking piston and hanger to destroke, and the rotary servo sleeve to turn counterclockwise. Now servo pressure is connected via port "P" and port "C1" to the bottom stroking cylinder and port "C2" and port "T" connecting the top stroking cylinder to case, ready to upstroke to the commanded position, as soon as the operating pressure falls below the override setting.

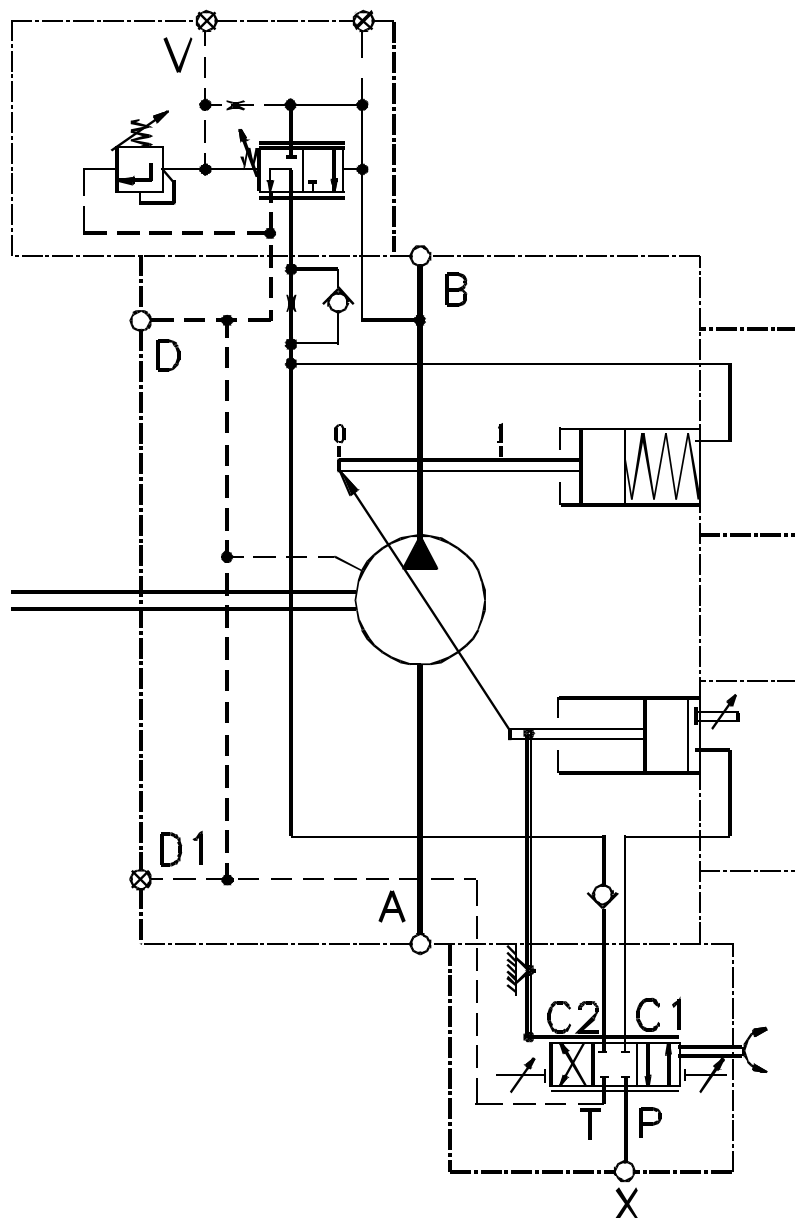

**R4P**

**SECONDARY CONTROL  
OPTIONS**

**WARNING:** Whenever a primary control "R", "H", or "E" is used with secondary control "P" or "T", where the pump will not be allowed to go to zero stroke, the installation of a special control piston cap must be used where a relief valve can be fitted to insure the pressure cannot reach system pressure "P". The relief valve shall be set to 1000 psi, 69 bar. The cap shall contain a flow limiting orifice (0.031", 0.79 mm), to limit the amount of oil escaping through this relief valve.

This orifice will limit the speed of compensator response both off-stroke and on-stroke, therefore a system relief valve is necessary to limit system pressure, and possibly an accumulator to maintain pressure during times of rapidly increasing demand.

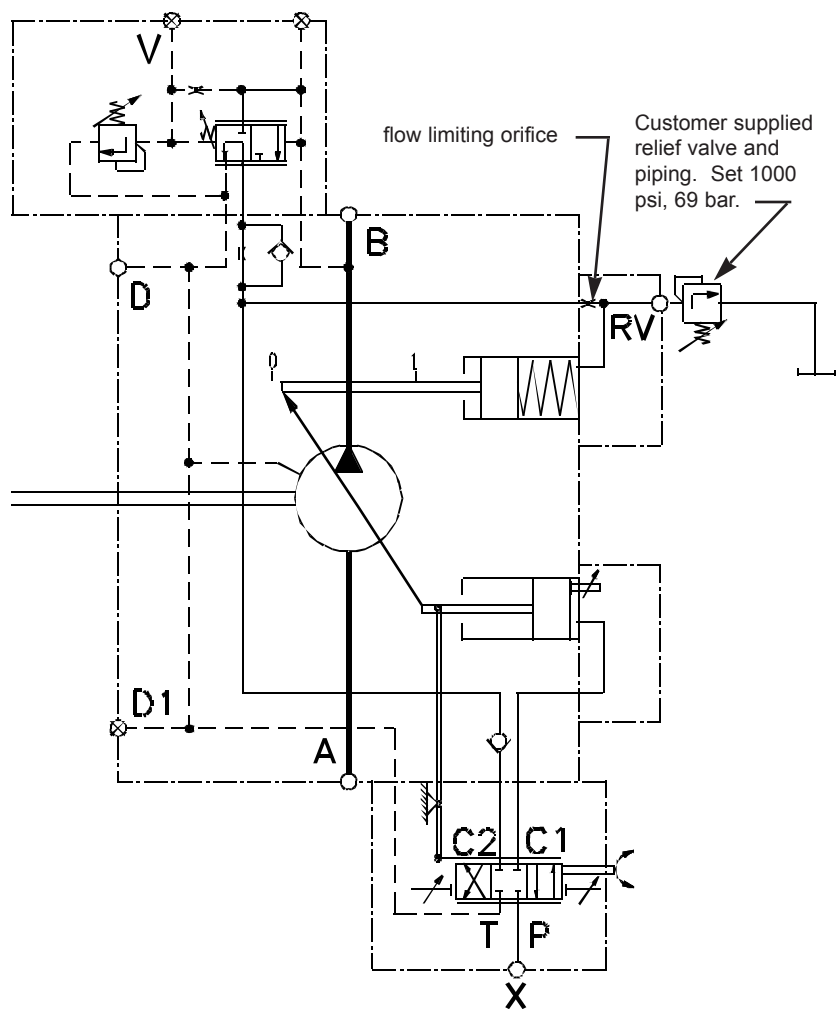

R4P with control relief valve and limiting orifice, for stop set above zero stroke

*Torque Limiter Override—  
Code T*

This option can be used as an output control with a rotary servo, hydraulic stroker or electrohydraulic stroker as an override when both pressure compensator and torque limiter overrides are available.

**WARNING:** Whenever a primary control “R”, “H”, or “E” is used with secondary control “P” or “T,” where the pump will not be allowed to go to zero stroke, the installation of a special control piston cap must be used where a relief valve can be fitted to insure the pressure cannot reach system pressure “P”. See circuit on page 14.

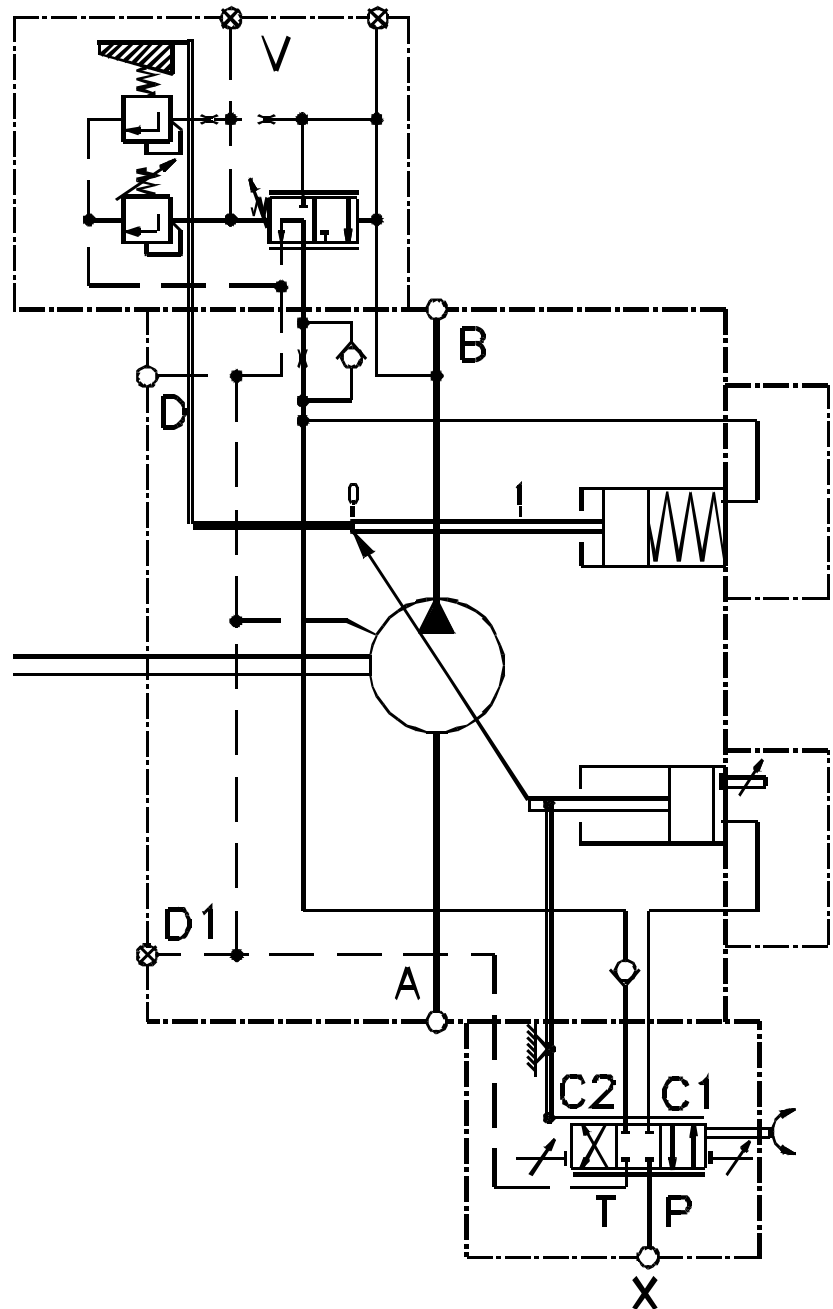

R4T

SERIES 6  
U.S. DATA

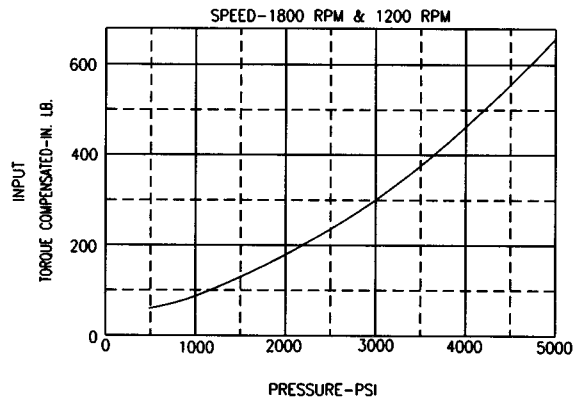
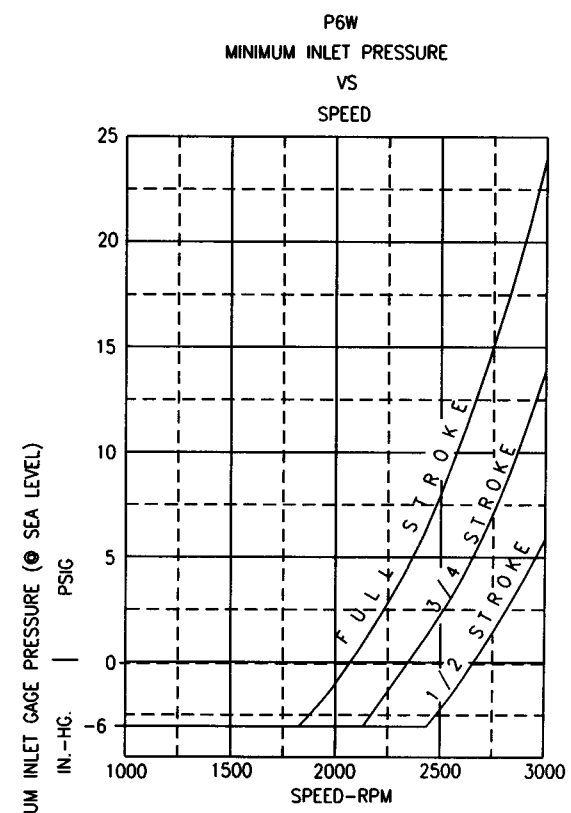
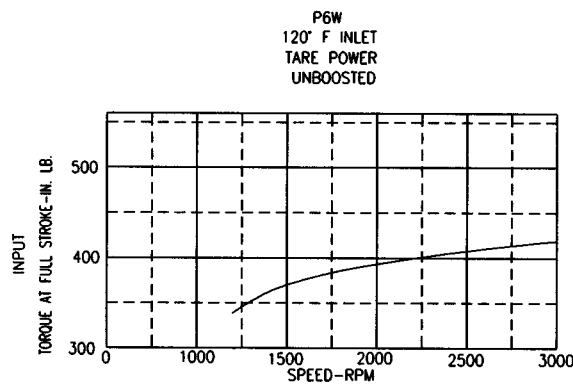
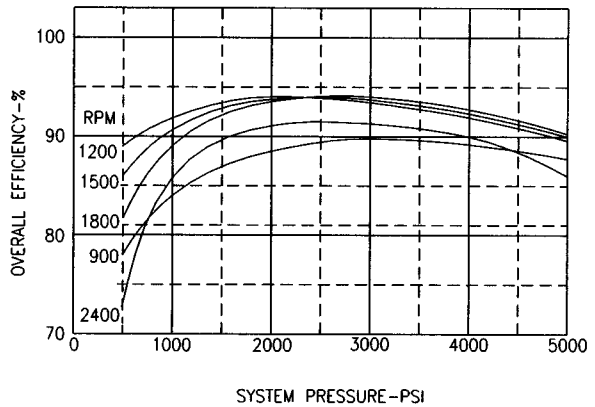
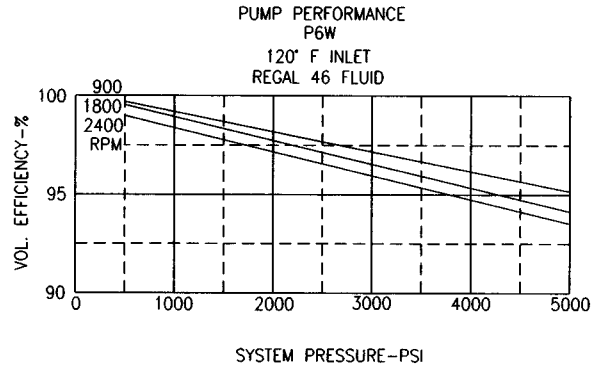
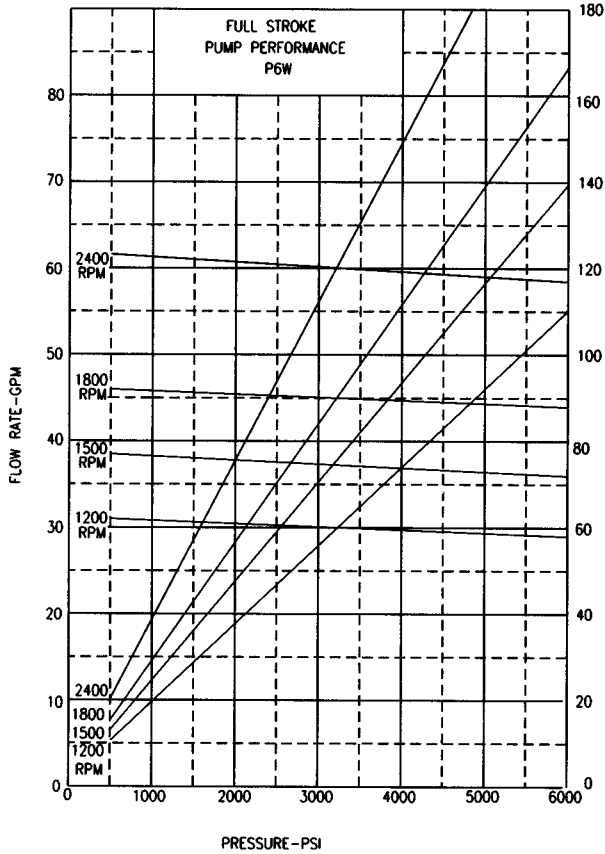

NOTE:  
MAXIMUM INLET PRESSURE 300 PSI



SERIES 6  
METRIC DATA

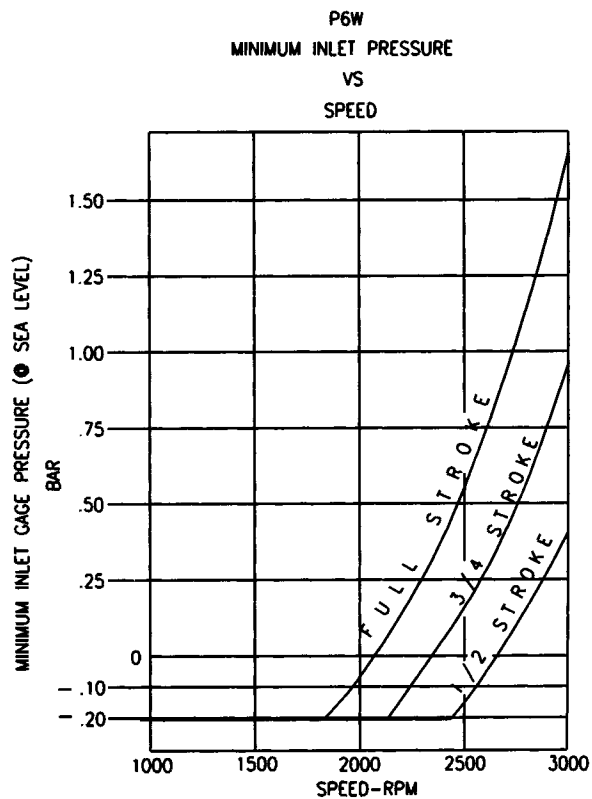
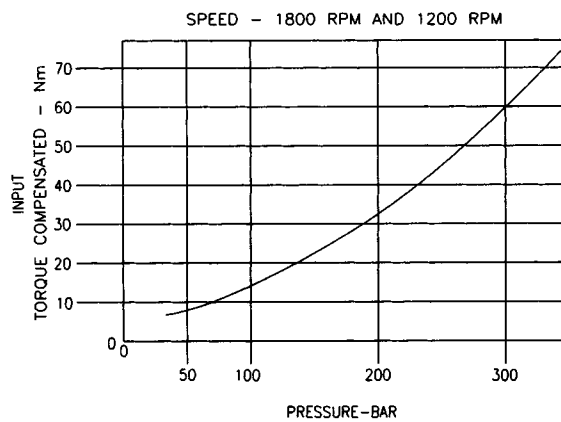
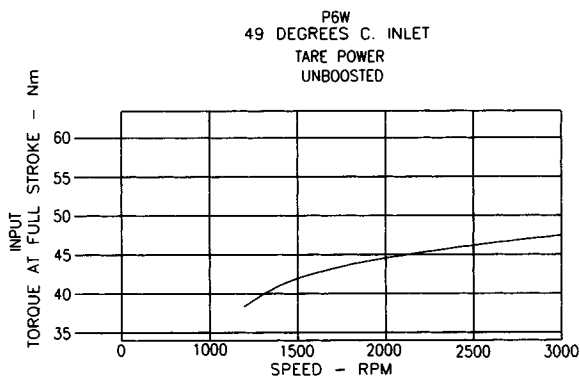
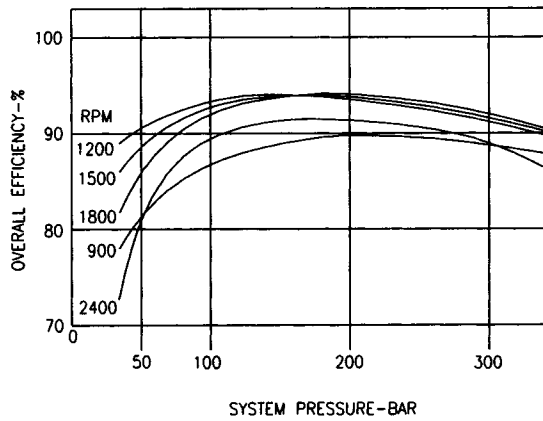
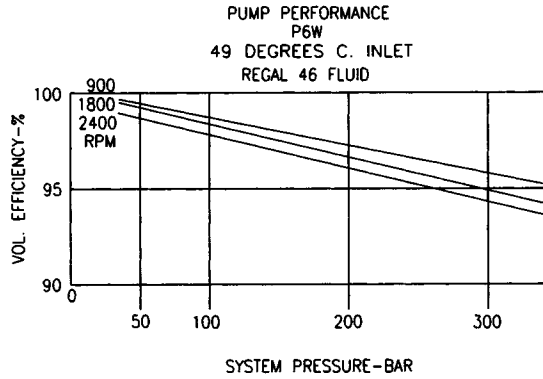
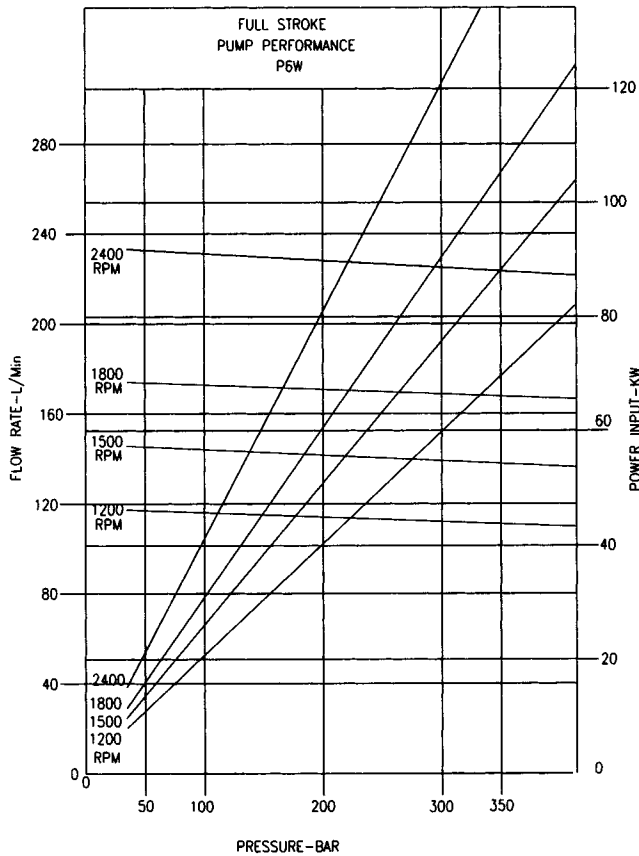

NOTE:  
MAXIMUM INLET PRESSURE 21 BAR

SERIES 7  
U.S. DATA

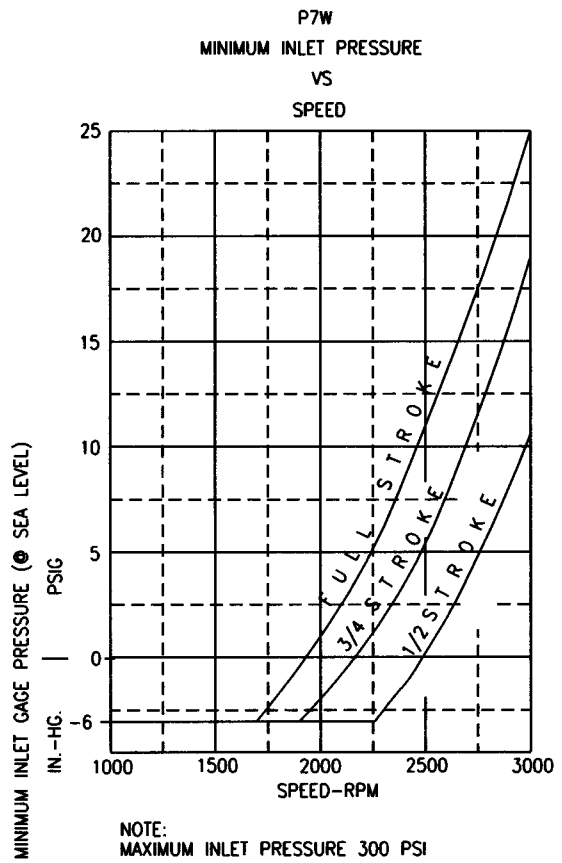
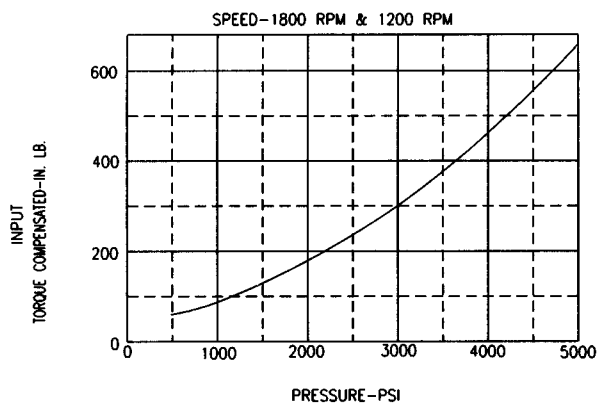
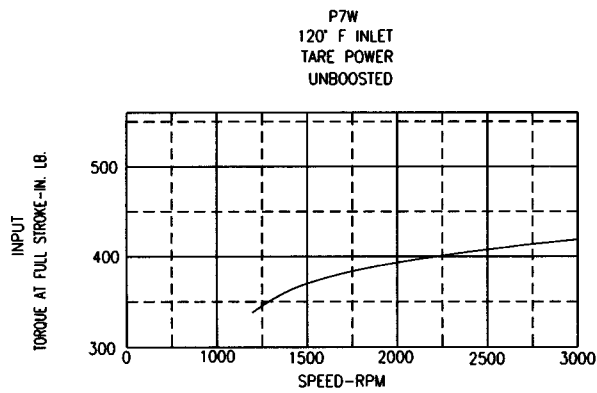
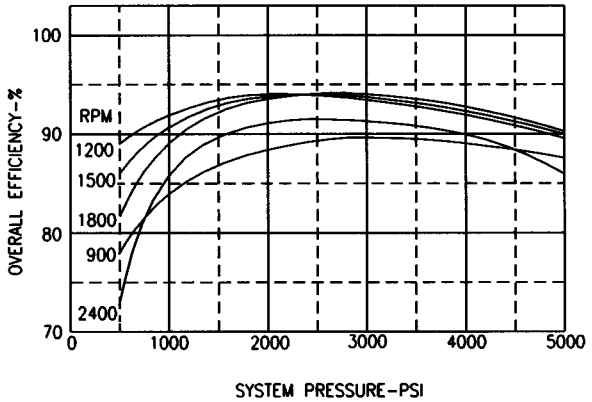
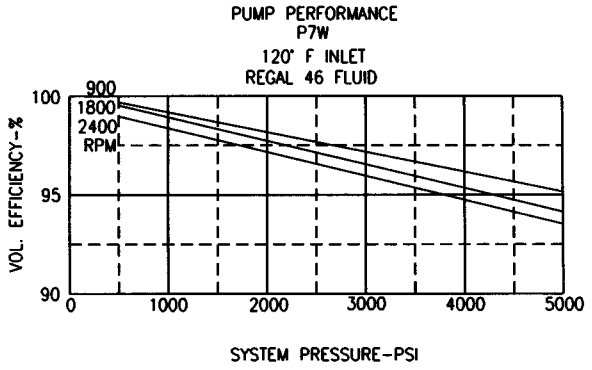
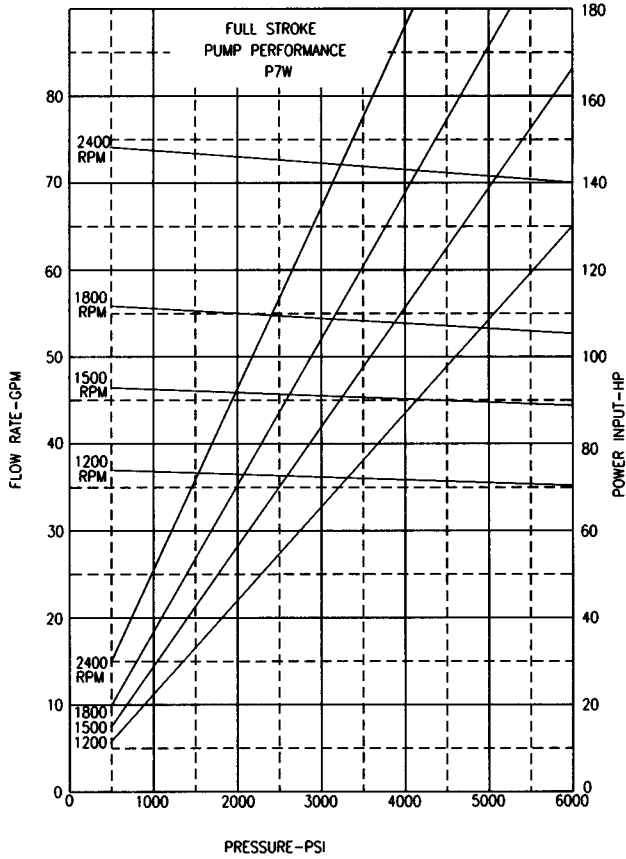

SERIES 7  
METRIC DATA

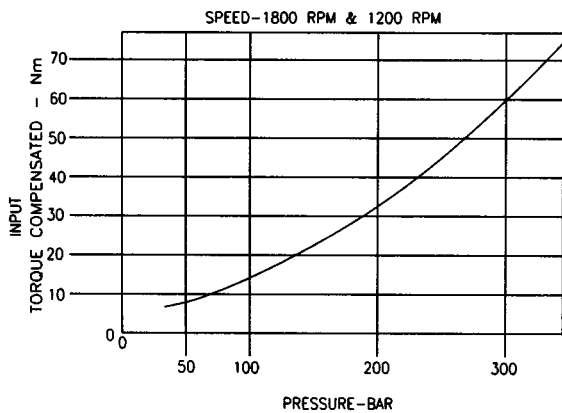
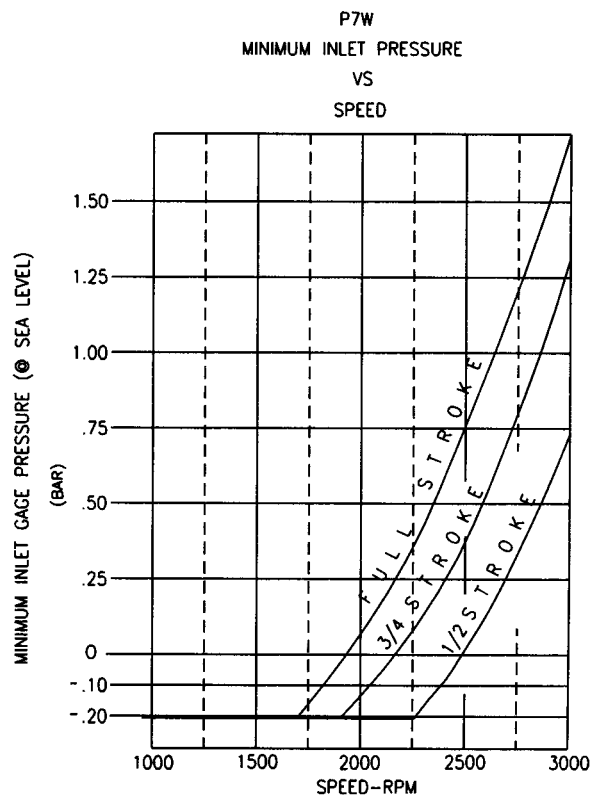
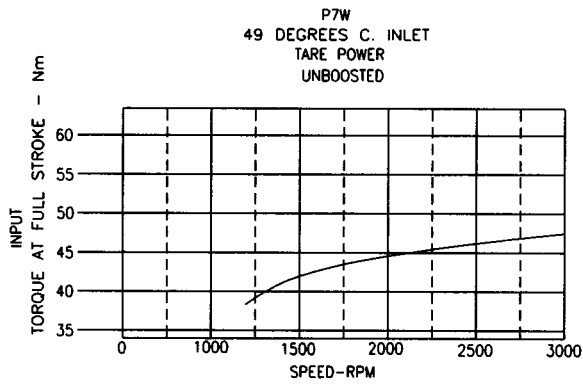
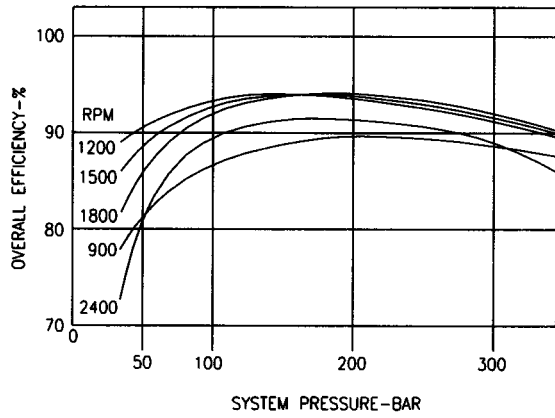
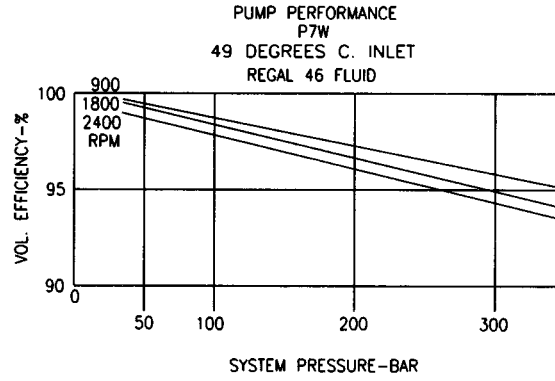
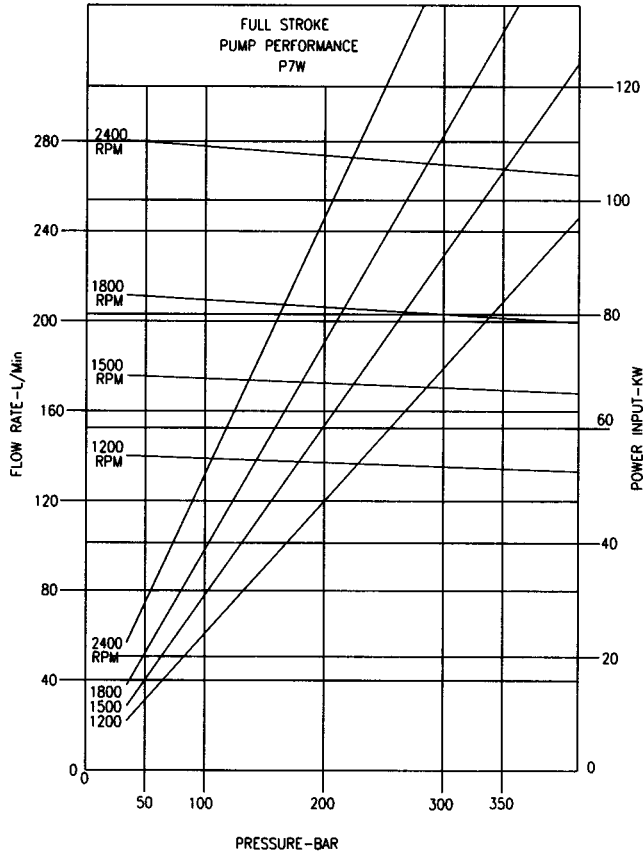

NOTE:  
MAXIMUM INLET PRESSURE 21 BAR

SERIES 8  
U.S. DATA

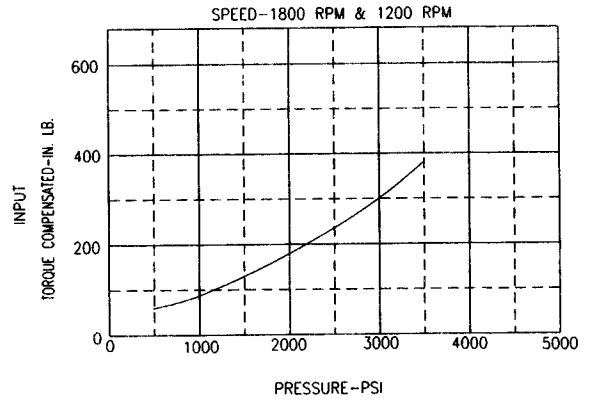
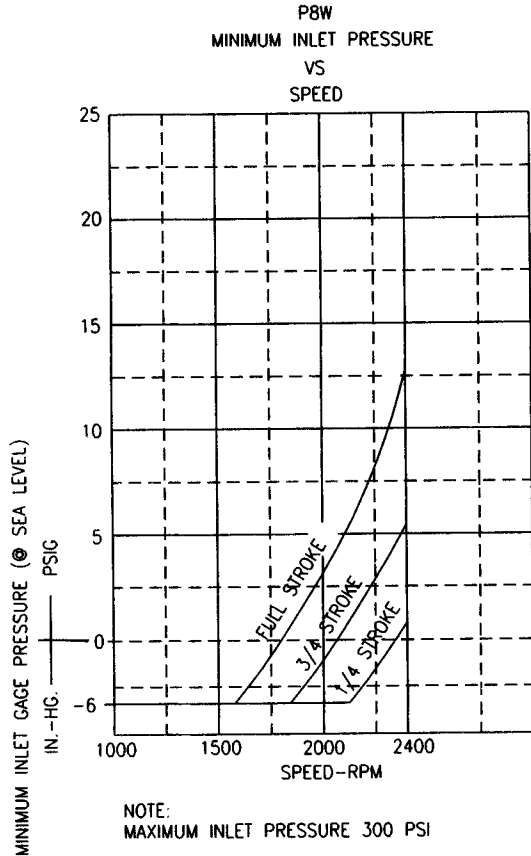
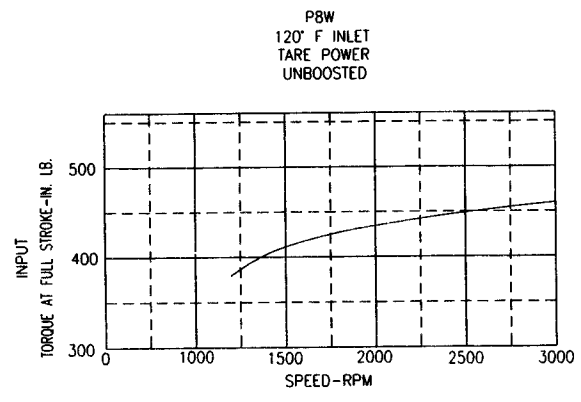
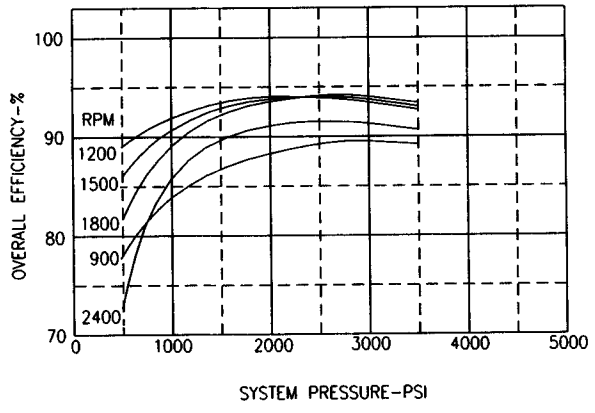
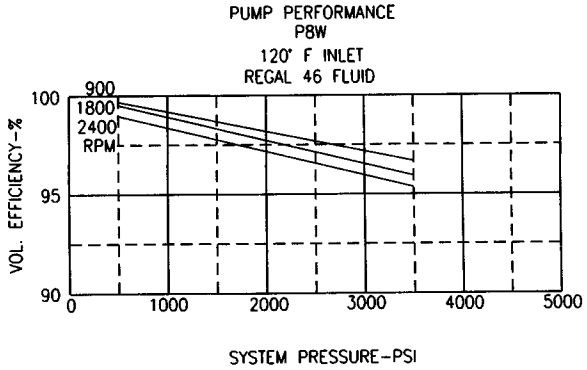
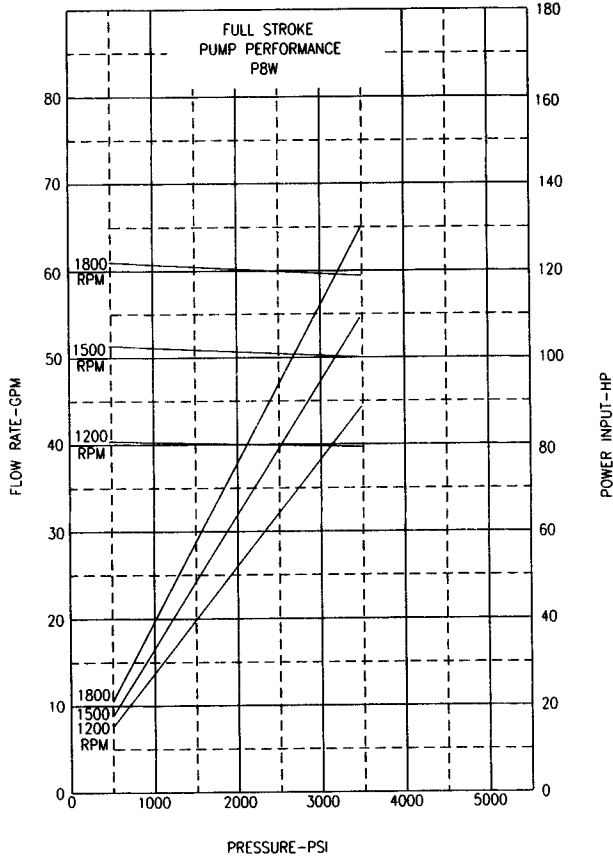

NOTE:  
MAXIMUM INLET PRESSURE 300 PSI

SERIES 8  
METRIC DATA

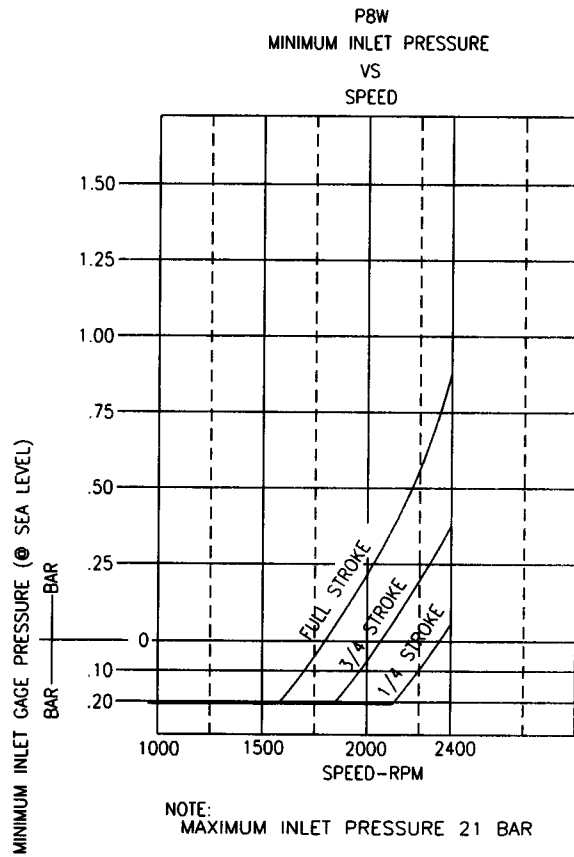
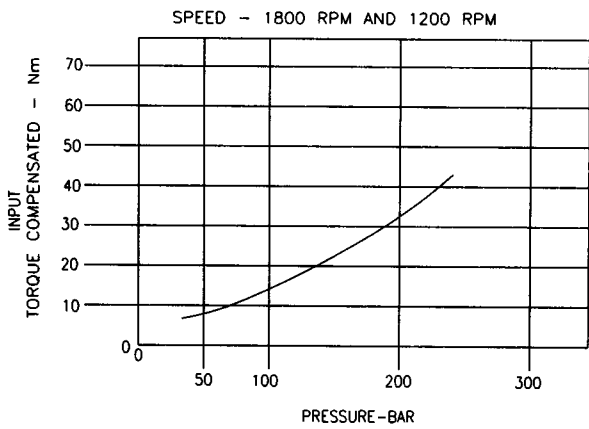
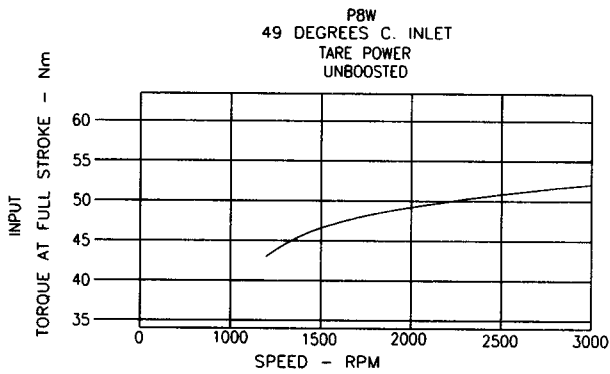
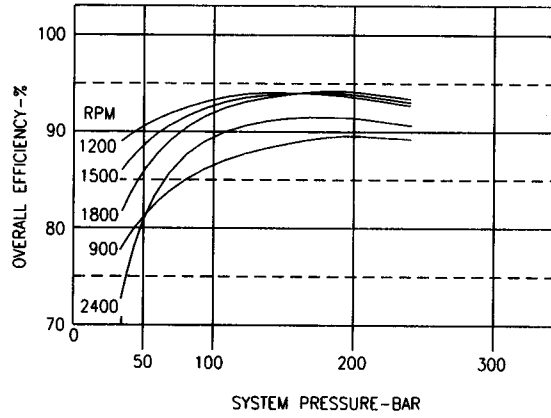
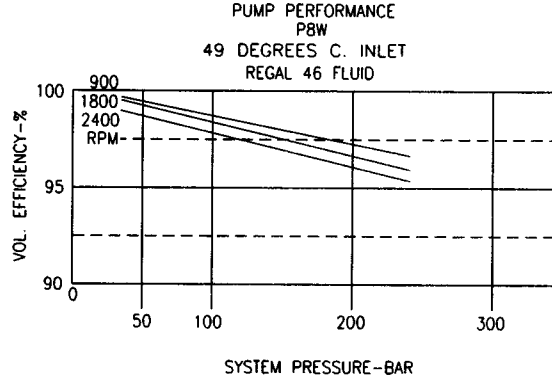
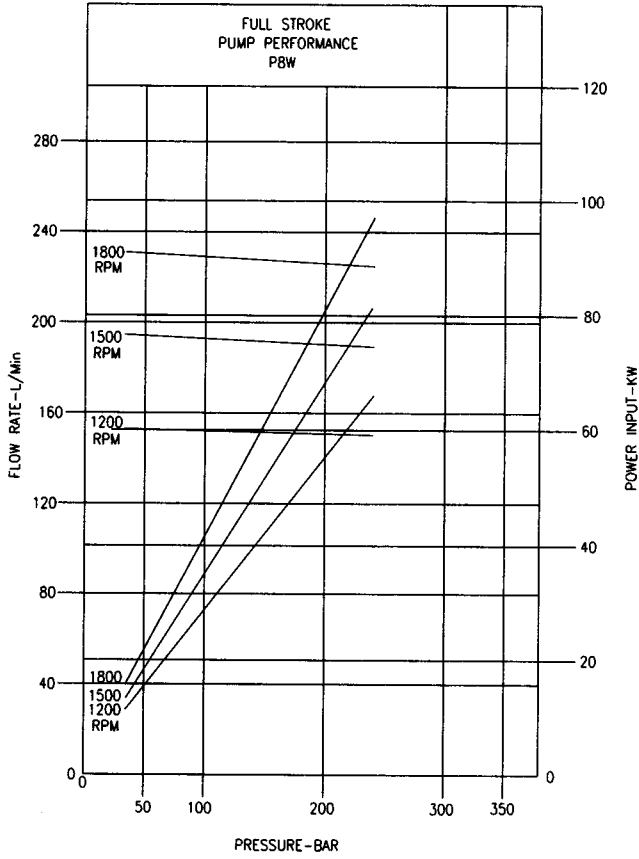

**FLUID CONNECTIONS**

• port A (inlet) SAE code 61 split flange	in. mm	2-1/2 (62,5)	2-1/2 (62,5)	2-1/2 (62,5)
• port B (system) SAE code 62 split flange	in. mm	1-1/4 31,25	1-1/4 31,25	1-1/4 31,25
• port D,D1 (case drain)	SAE	-16	-16	-16
• port LS (load sensing port)	SAE	-4	-4	-4
• port V (compensator vent)	SAE	-6	-6	-6
• port X (rotary servo)	SAE	-6	-6	-6
• port E, H (rotary servo electric & hydraulic stroker inlet)	SAE	-4	-4	-4
• <u>port RV (cylinder relief port)</u>	<u>SAE</u>	<u>-4</u>	<u>-4</u>	<u>-4</u>

# INSTALLATION DRAWING

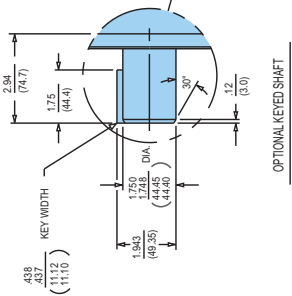
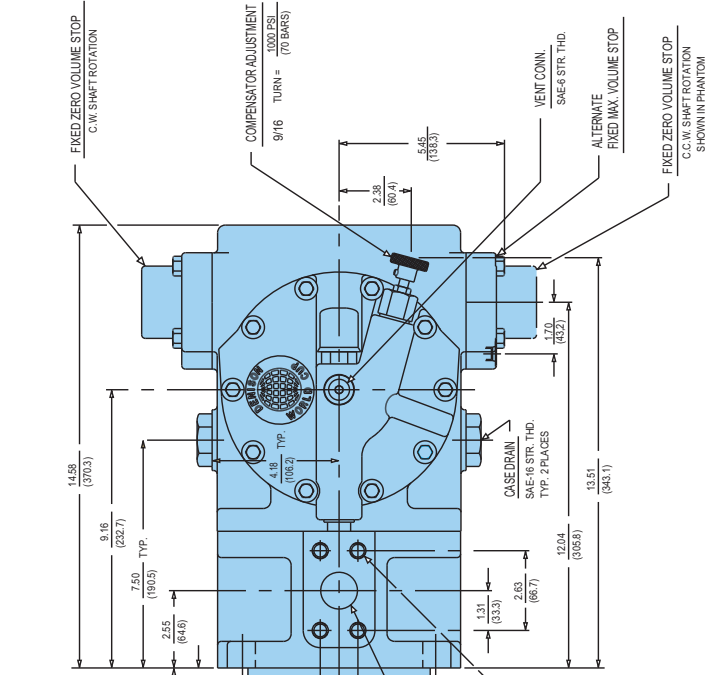
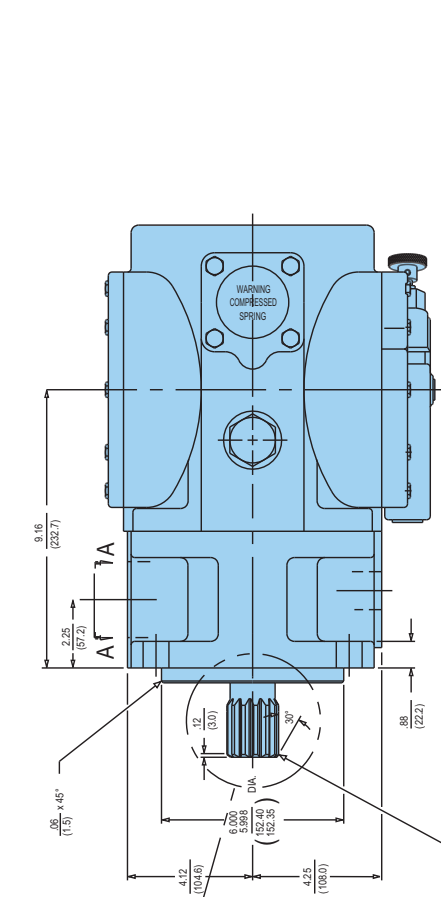
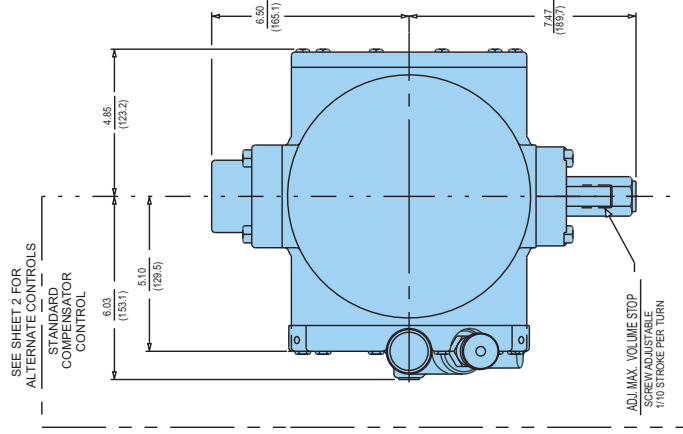
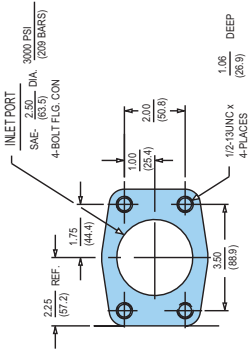

SAE INVOLUTE SPINE DATA #8848 1869  
FLAT ROOT SIDE FIT EXTERNAL CLASS 1  
8/16 PITCH  
3° PRESSURE ANGLE  
13 TEETH  
3.18 (80.8) MAJOR DIA.  
(43.71-43.586)

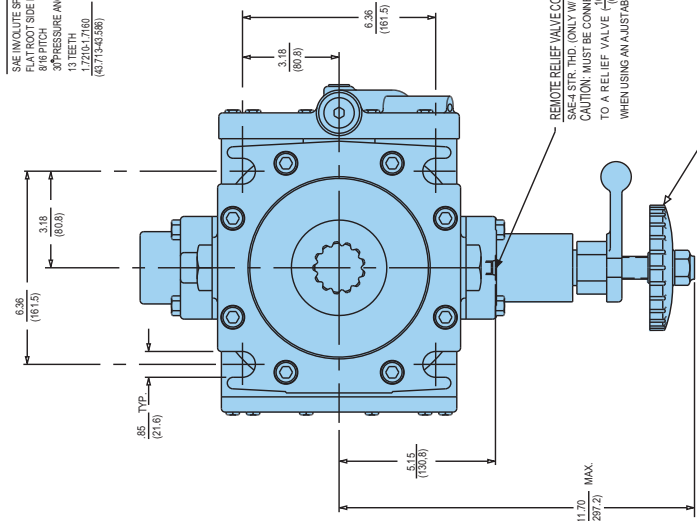

-PUMP INSTALLATION-  
AXIAL PISTON, VAR VOL. ONE SIDE CENTER,  
COMPENSATOR CONTROLS w/SAE "D" DRIVE SHAFT  
& MOUNTING FLANGE  
DRAWING #23-9583

# INSTALLATION DRAWING

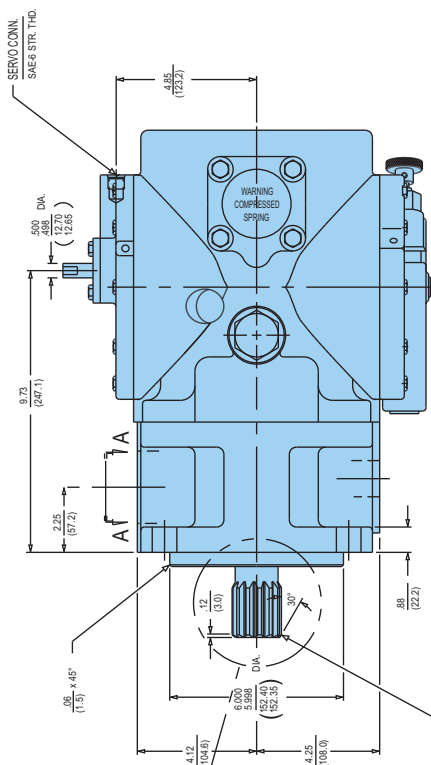
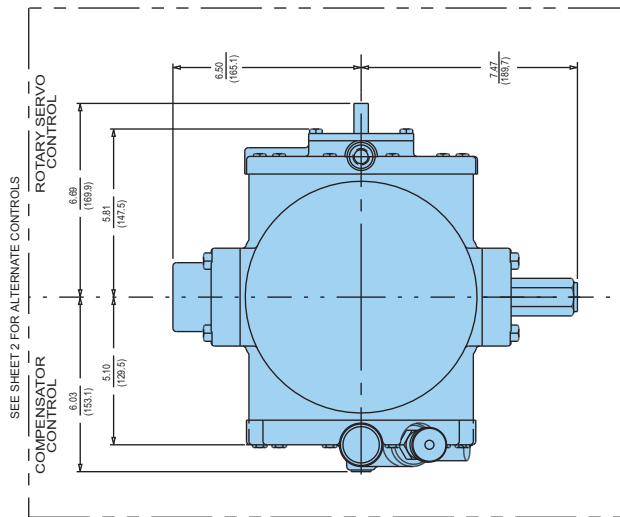
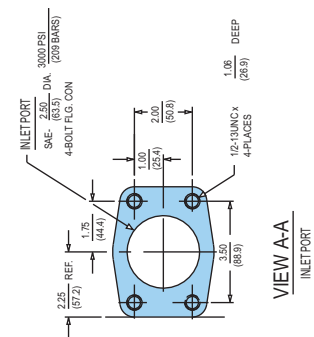

SAE INVOIUTE SPINE DATA #48-B11889  
FIT FOOT SIDE FIT EXTERNAL CLASS-1  
3° PRESSURE ANGLE  
13 TEETH  
1.720 x 1.760 - MAJOR DIA.  
(4.371-4.388)

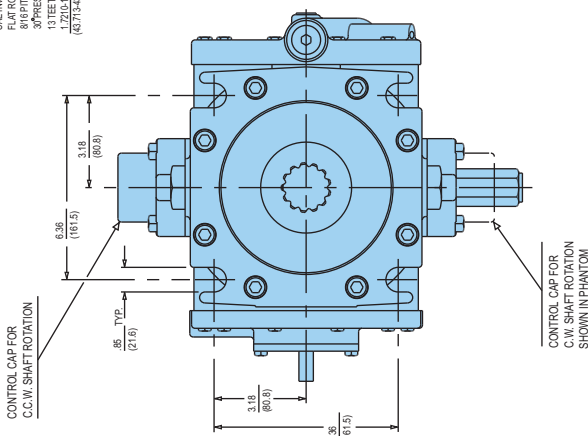
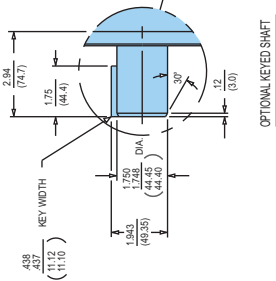
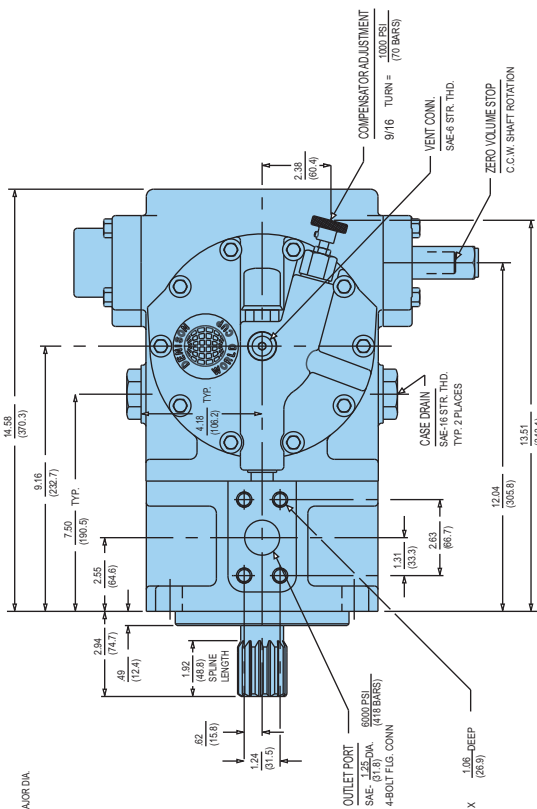

**\*Warning:** Whenever a primary control "R", "H" or "E" is used with secondary control "P" or "T", where the pump will not be allowed to go to zero stroke, a special control piston cap must be used where a relief valve may be connected to port "RV" and set to 1000 psi, .69 bar maximum.

- PUMP INSTALLATION -  
AXIAL PISTON, VAR VOL. ONE SIDE CENTER,  
SERVO CONTROLS w/ & w/o OVERRIDE CON-  
TROLS,  
w/SAE "D" DRIVE SHAFT & MOUNTING FLANGE  
DRAWING #23-9614



# INSTALLATION DRAWING

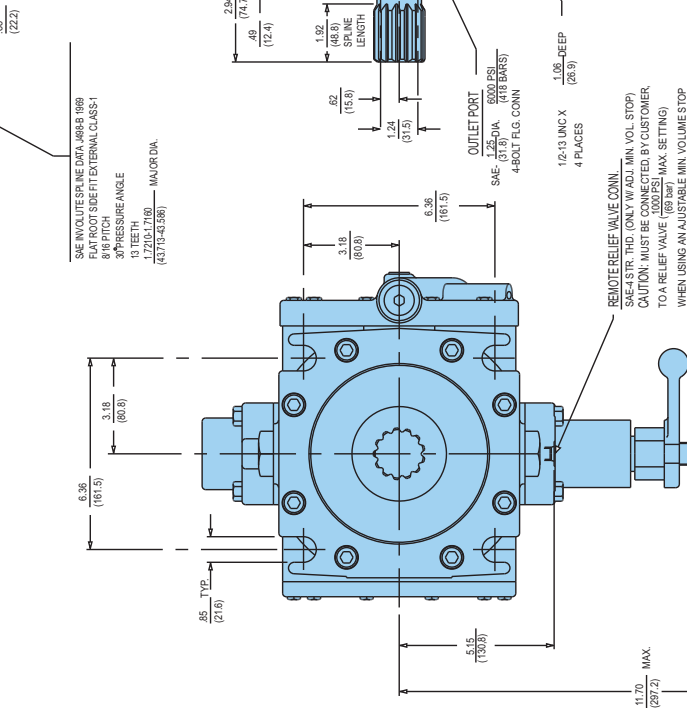
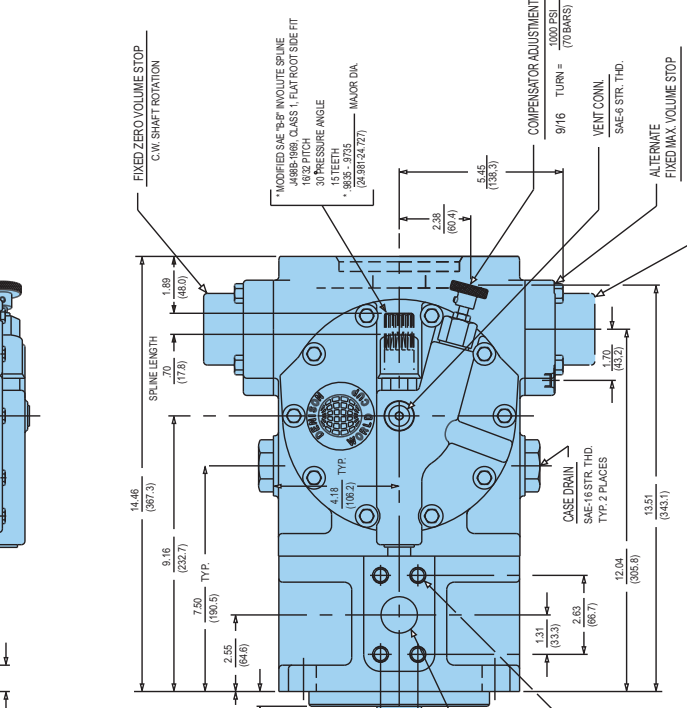
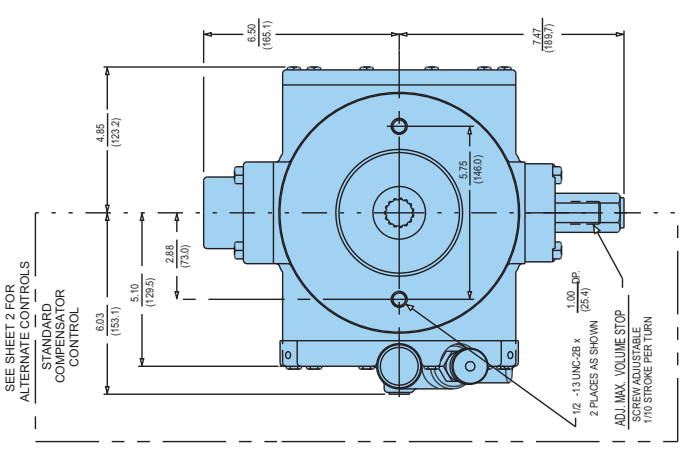
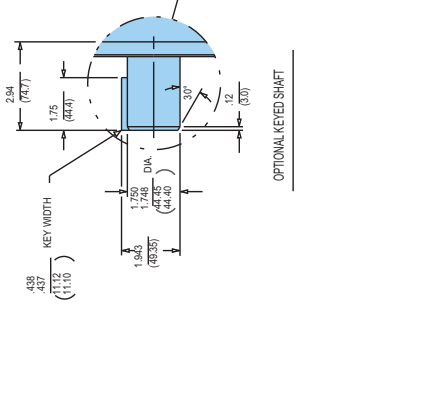
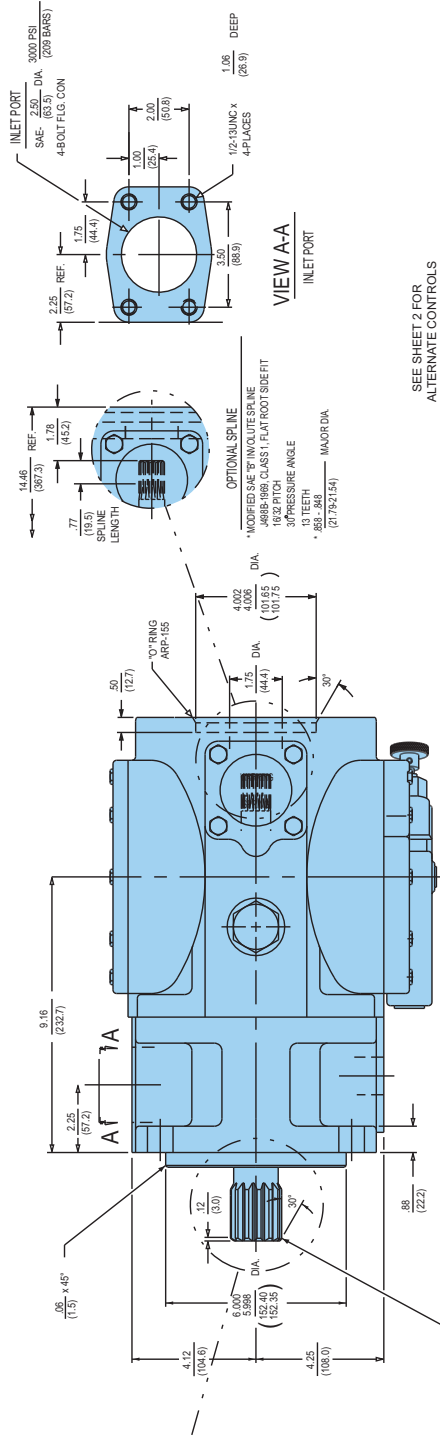

-PUMP INSTALLATION-  
AXIAL PISTON, VAR VOL. ONE SIDE CENTER,  
COMPENSATOR CONTROLS SAE "D" DRIVE SHAFT  
& MTG FLANGE, W/SAE "B" OR "BB" AUX. MTG.  
DRAWING #23-9584

# INSTALLATION DRAWING

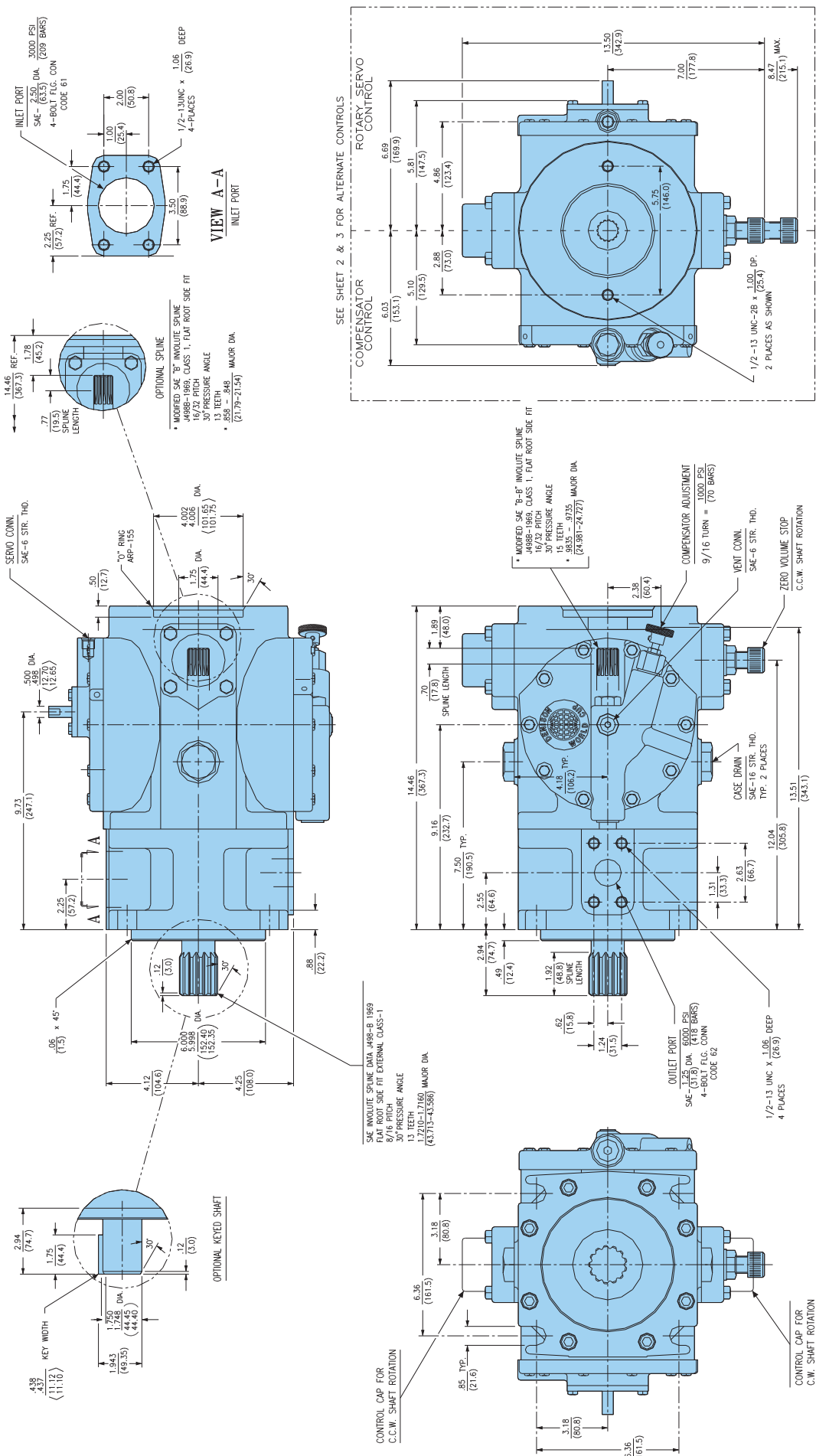

**\*Warning:** Whenever a primary control "R", "H" or "E" is used with secondary control "P" or "T", where the pump will not be allowed to go to zero stroke, a special control piston cap must be used where a relief valve may be connected to port "RV" and set to 1000 psi .69 bar maximum.

**\*Warning:** Whenever a primary control "R", "H" or "E" is used with secondary control "P" or "T", where the pump will not be allowed to go to zero stroke, a special control piston cap must be used where a relief valve may be connected to port "RV" and set to 1000 psi .69 bar maximum.

**\*Warning:** Whenever a primary control "R", "H" or "E" is used with secondary control "P" or "T", where the pump will not be allowed to go to zero stroke, a special control piston cap must be used where a relief valve may be connected to port "RV" and set to 1000 psi .69 bar maximum.

**\*Warning:** Whenever a primary control "R", "H" or "E" is used with secondary control "P" or "T", where the pump will not be allowed to go to zero stroke, a special control piston cap must be used where a relief valve may be connected to port "RV" and set to 1000 psi .69 bar maximum.

**\*Warning:** Whenever a primary control "R", "H" or "E" is used with secondary control "P" or "T", where the pump will not be allowed to go to zero stroke, a special control piston cap must be used where a relief valve may be connected to port "RV" and set to 1000 psi .69 bar maximum.

**\*Warning:** Whenever a primary control "R", "H" or "E" is used with secondary control "P" or "T", where the pump will not be allowed to go to zero stroke, a special control piston cap must be used where a relief valve may be connected to port "RV" and set to 1000 psi .69 bar maximum.

**\*Warning:** Whenever a primary control "R", "H" or "E" is used with secondary control "P" or "T", where the pump will not be allowed to go to zero stroke, a special control piston cap must be used where a relief valve may be connected to port "RV" and set to 1000 psi .69 bar maximum.

**\*Warning:** Whenever a primary control "R", "H" or "E" is used with secondary control "P" or "T", where the pump will not be allowed to go to zero stroke, a special control piston cap must be used where a relief valve may be connected to port "RV" and set to 1000 psi .69 bar maximum.

**\*Warning:** Whenever a primary control "R", "H" or "E" is used with secondary control "P" or "T", where the pump will not be allowed to go to zero stroke, a special control piston cap must be used where a relief valve may be connected to port "RV" and set to 1000 psi .69 bar maximum.

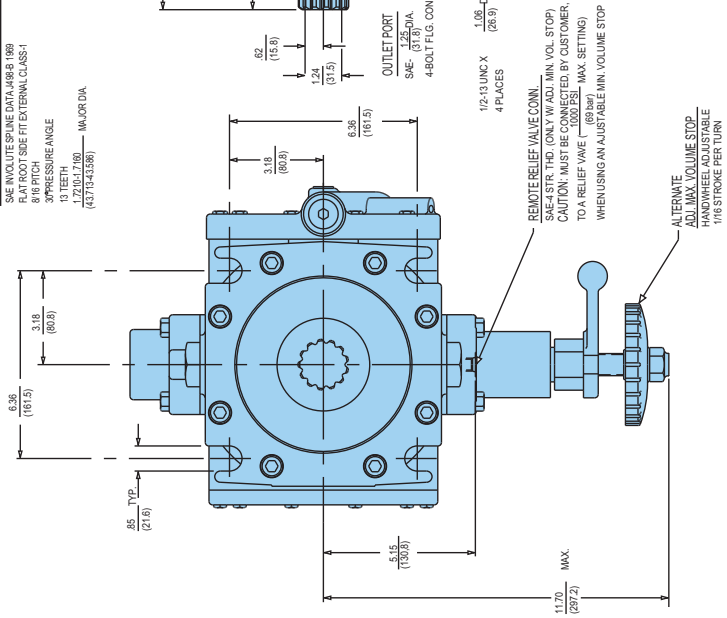
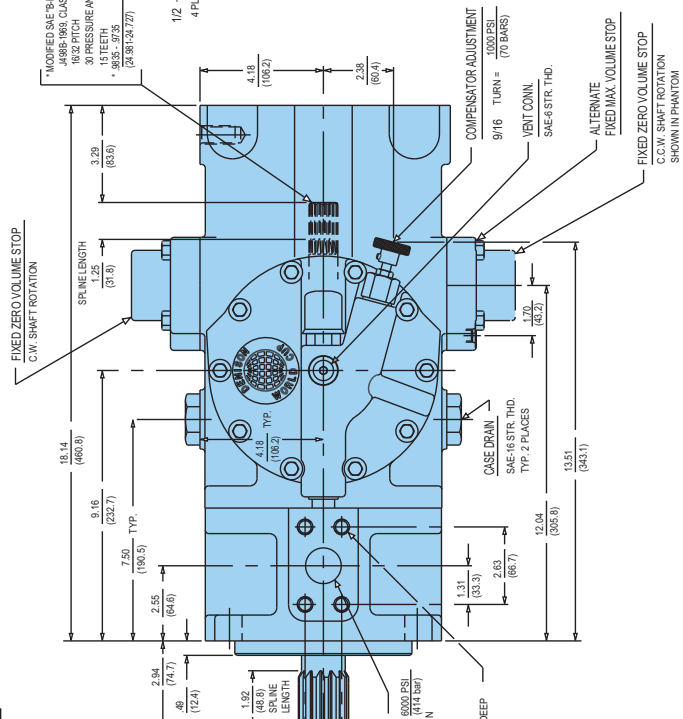
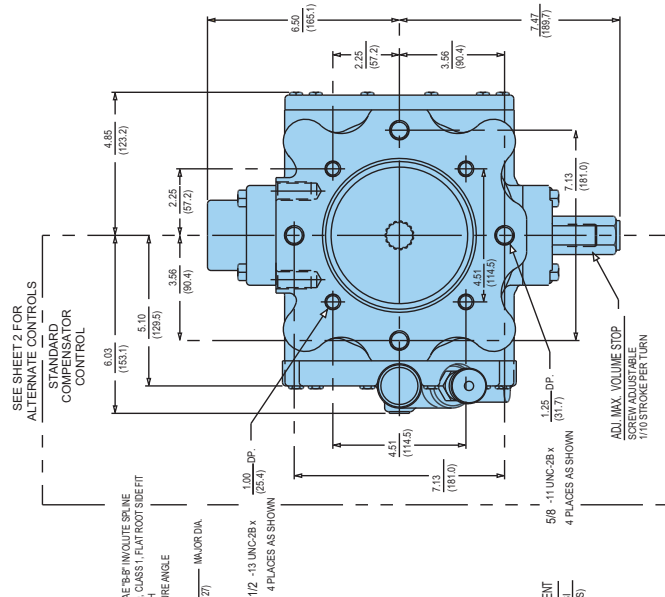
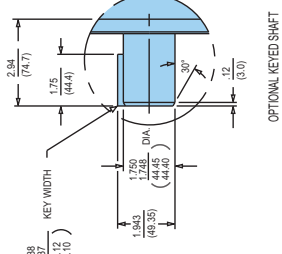
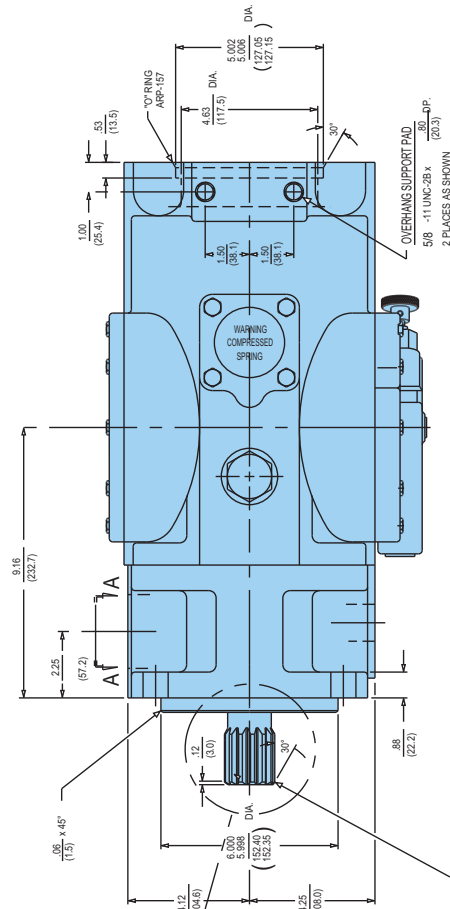
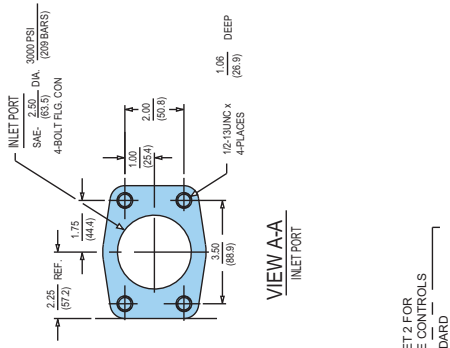

-PUMP INSTALLATION-  
AXIAL PISTON, VAR VOL., ONE SIDE CENTER,  
COMPENSATOR CONTROLS SAE "D" DRIVE SHAFT  
& MTG FLANGE, w/SAE "C" AUX MTG  
DRAWING #23-9617

# INSTALLATION DRAWING

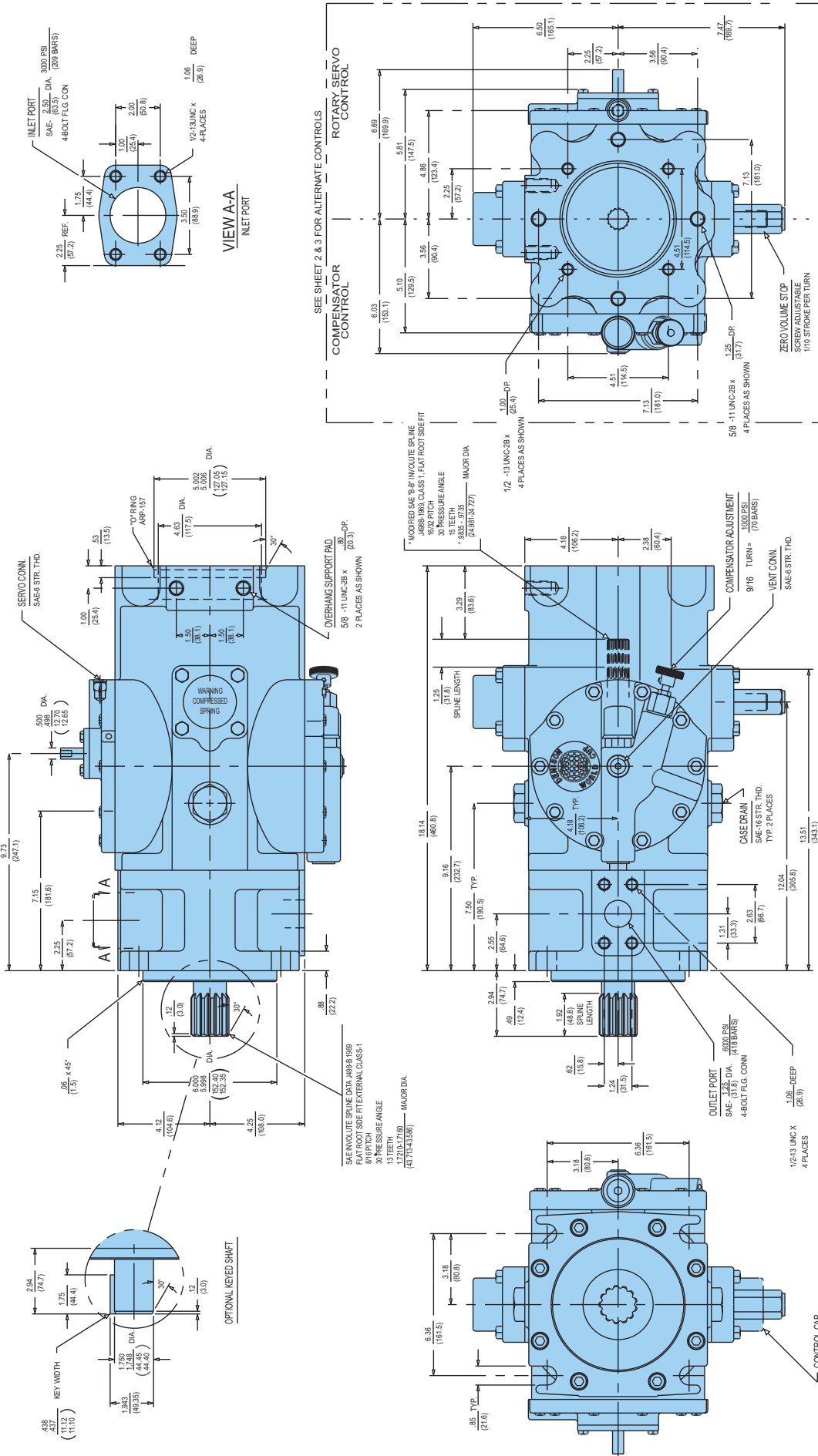

-PUMP INSTALLATION-  
AXIAL PISTON, VAR VOL. ONE SIDE CENTER,  
SERVO CONTROLS w/ w/o OVERRIDE CONTROLS  
SAE "D" DRIVE SHAFT & MTG FLANGE W/SAE "C" AUX MTG  
DRAWING #23-9624

**\*Warning:** Whenever a primary control "R", "H", or "E" is used with secondary control "P" or "T", where the pump will not be allowed to go to zero stroke, a special control piston cap must be used where a relief valve may be connected to port "RV" and set to 1000 psi. .69 bar maximum.

# INSTALLATION DRAWING

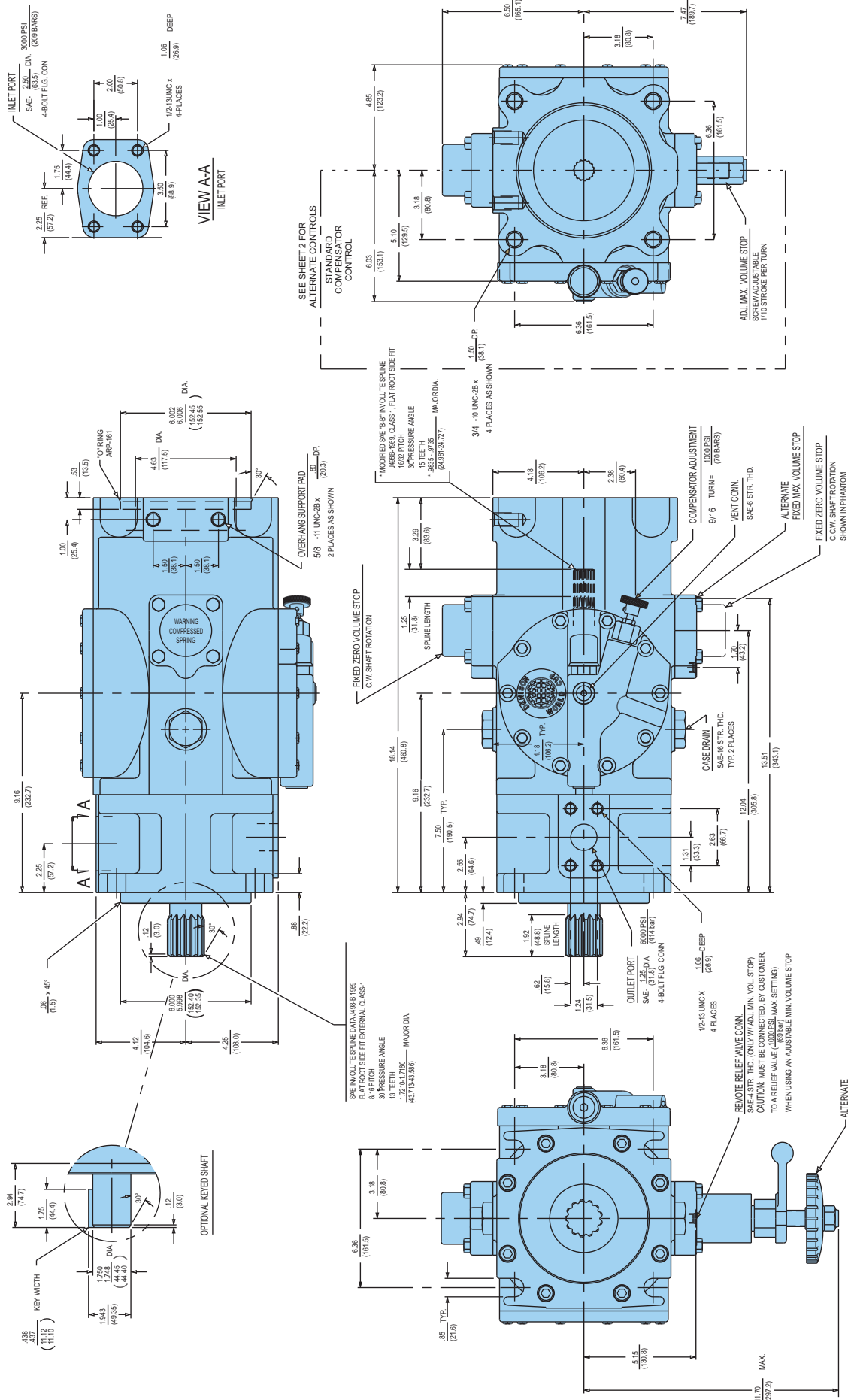

-PUMP INSTALLATION-  
AXIAL PISTON, VAR VOL., ONE SIDE CENTER,  
COMPENSATOR CONTROLS w/SAE "D" DRIVE SHAFT  
& MTG FLANGE, w/SAE "D" AUX MTG  
DRAWING #23-9618



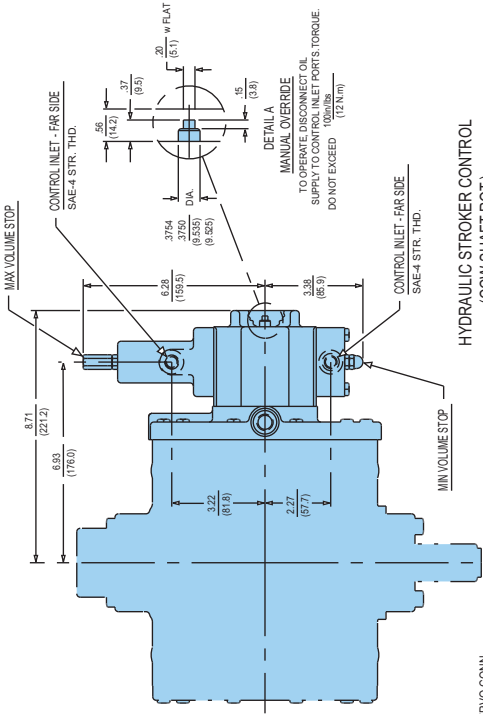

HYDRAULIC STROKER CONTROL  
(CW SHAFT ROT.)  
w/ MIN. & MAX. VOLUME ADJUSTMENT

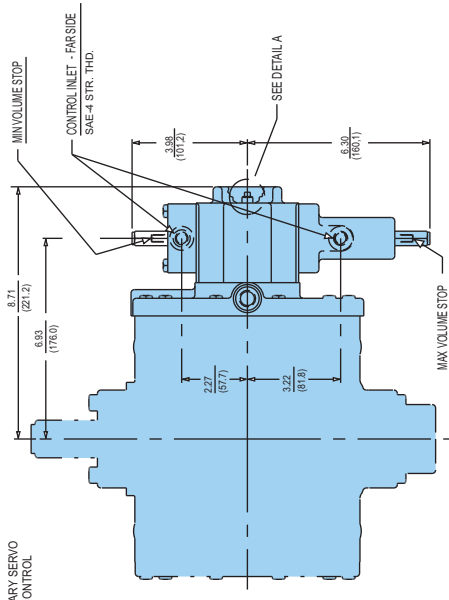

HYDRAULIC STROKER CONTROL  
(CW SHAFT ROT.)  
w/ MIN. & MAX. VOLUME ADJUSTMENT

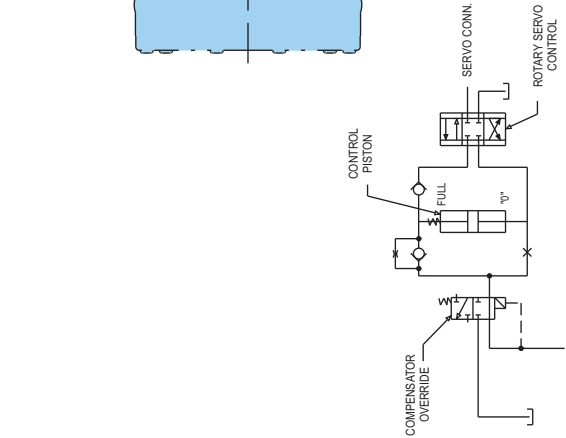

ROTARY SERVO CONTROL  
w/ MIN. & MAX. STOPS  
(CW SHAFT ROT.)

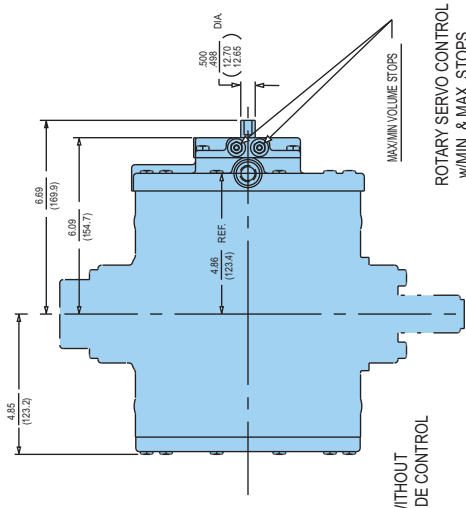

WITHOUT  
OVERRIDE CONTROL

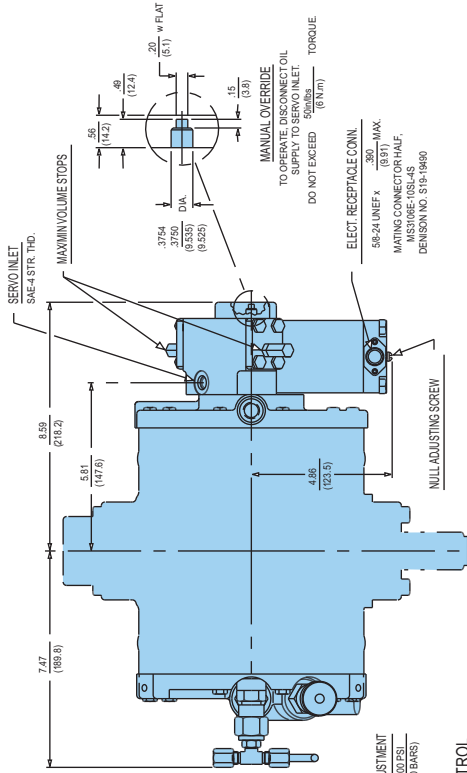

ELECTRO HYDRAULIC STROKER  
(CW SHAFT ROT.)  
w/ MIN. & MAX. VOLUME ADJUSTMENT

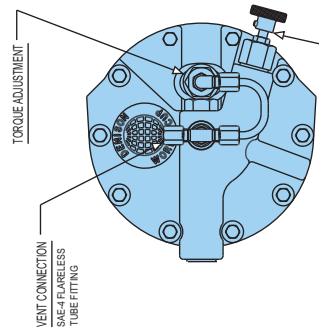
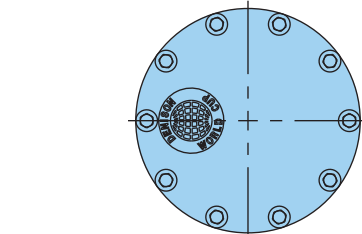

COMPENSATOR ADJUSTMENT  
1000 PSI.  
9/16 TURN = 70 BARS

COMPENSATOR CONTROL  
w/ TORQUE LIMITER

-PUMP INSTALLATION-  
AXIAL PISTON, VAR VOL. ONE SIDE CENTER,  
SERVO CONTROLS SAE "D" DRIVE SHAFT  
& MTIG FLANGE, w & w/o OVERRIDE CONTROLS,  
SAE "D" DRIVE SHAFT w/SAE "B" OR "BB" AUX MTG  
DRAWING #23-9614

**World Cup pumps**

**Model number sheet**

Example model code:

Revised 6/24/02

	P	6	W	-2	R	1	*	-C	0	0	-BB	0	
<b>Pump</b>	P												
<b>Displacement</b>													
6.00 cu.in./rev. (98 cc/rev.)		6											
7.25 cu.in./rev. (119 cc/rev.)		7											
8.00 cu.in./rev. (131 cc/rev.)		8											
<b>Type</b>													
Standard version			W										
Test stand version			T										
<b>Shaft</b>													
Splined SAE-D (for W type pumps only)				-1									
Keyed SAE-D (for W type pumps only)				-2									
Splined AND-10266 (for T type pumps only)				-3									
<b>Rotation</b>													
Clockwise					R								
Counter-clockwise					L								
<b>Seals</b>													
Nitrile (Buna N)						1							
EPR (not available when using "E" primary control)(pump will be unpainted unless other						4							
Flouorocarbon (Viton)						5							
Military specification MIL-P-25732						6							
<b>Design letter</b> (assigned by manufacturer) *													
<b>Primary controls</b>													
Compensator								-C					
Load sensing compensator (50 PSI pressure drop)								-L					
Load sensing compensator (200 PSI pressure drop)								-M					
Rotary servo								-R					
Torque limiter								-T					
Hydraulic servo								-H					
Electro-hydraulic servo								-E					
<b>Primary control options</b>													
None (for C, L, M, R, & T primary controls only)										0			
Maximum volume screw (for C, L, M, & T primary controls only)										1			
Maximum volume handwheel (for C, L, M, & T primary controls only)										2			
Remote access volume adjustment (for C & T primary controls only)										3			
Maximum & minimum volume adjustment (for R, H, & E primary controls only)										4			
<b>Secondary controls</b>													
None											0		
Compensator override (for R, H, & E primary controls only)											P		
Torque limiter override (for R, H, & E primary controls only)											T		
Note: Whenever P or T are chosen, if you have an application where the pump will not be allowed to go to zero stroke, the installation of a special control piston cap must be used so that a relief valve can be fitted to ensure the pressure cannot reach system pressure. See circuit on page 14 of sales catalog.													
<b>External drive</b>													
None												-0	
SAE-B (SAE 101-2) with SAE-B (SAE 22-4) coupling												-B	
SAE-B (SAE 101-2) with SAE-BB (SAE 25-4) coupling												-BB	
SAE-C (SAE 127-4) with SAE-C (SAE 32-4) coupling												-C	
SAE-D (SAE 152-4) with SAE-D (SAE 44-4) coupling												-D	
<b>External mounting</b>													
No external pump mounted													0
External pump mounted (requires special modification "-M2")(must be separately specified)													1
<b>Special modification</b>													
None													omit
No paint													-NP
Other special modification (example: tandem pumps)													-M2
<b>Allowable controls</b>													
C00,C10,C20,C30,L00,L10,L20,M00,M10,M20													
T00,T10,T20,T30,R00,R40,ROP,R4P,ROT,R4T													
E40,E4P,E4T,H40,H4P,H4T													



**DEFINITION & UNIT**

<i>displacement</i>	$\text{in}^3/\text{rev} \times 16.387 = \text{cm}^3/\text{rev}$	$\text{cm}^3/\text{rev} \times 0.06102 = \text{in}^3/\text{rev}$
<i>flow</i>	$\text{gpm} \times 3.78 = \text{L}/\text{min}$	$\text{L}/\text{min} \times 0.2642 = \text{gpm}$
<i>power</i>	$\text{hp} \times 0.7457 = \text{kW}$	$\text{kW} \times 1.341 = \text{hp}$
<i>torque</i>	$\text{lb-ft} \times 1.3567 = \text{Nm}$	$\text{Nm} \times 0.7376 = \text{lb-ft}$
<i>pressure</i>	$\text{lbs}/\text{in}^2 \text{ (psi)} \times 0.06895 = \text{bar}$ $\text{lbs}/\text{in}^2 \text{ (psi)} \times 6.895 = \text{kPa}$	$\text{bar} \times 14.50 = \text{lbs}/\text{in}^2 \text{ (psi)}$ $\text{kPa} \times 0.1450 = \text{lbs}/\text{in}^2 \text{ (psi)}$
<i>weight</i>	$\text{lb} \times 0.4536 = \text{kg}$	$\text{kg} \times 2.205 = \text{lbs}$
<i>force</i>	$\text{lb} \times 4.448 = \text{N}$	$\text{N} \times 0.2248 = \text{lbs}$
<i>volume</i>	$\text{in}^3 \times 16.387 = \text{cm}^3$	$\text{cm}^3 \times 0.06102 = \text{in}^3$
<i>area</i>	$\text{in}^2 \times 6.452 = \text{cm}^2$	$\text{cm}^2 \times 0.1550 = \text{in}^2$
<i>length</i>	$\text{in} \times 25.4 = \text{mm}$	$\text{mm} \times 0.03937 = \text{in}$
<i>temperature</i>	$\text{degree F-32} = \text{°C}$ 1.8	$1.8 \times (\text{°C}+32) = \text{° F}$
<i>viscosity</i>	$\text{cSt} \times 1.0 = \text{mm}^2/\text{sec}$ $\text{SSU} \cong \text{cSt} \times 4.25 + 14$	$\text{mm}^2/\text{sec} \times 1.0 = \text{cSt}$ $20 \text{ cSt} \cong 99 \text{ SSU}$

**FLUID POWER FORMULAS**

<i>Pump input torque</i>	<i>lbs. in.</i>	$\frac{\text{pressure}(\text{psi}) \times \text{displacement} (\text{in}^3/\text{rev})}{2p \times \text{mech. eff.}}$
<i>Pump input power</i>	<i>hp</i>	$\frac{\text{rpm} \times (\text{in}^3/\text{rev}) \times (\text{psi})}{395934 \times \text{overall eff.}}$
<i>Pump output flow</i>	<i>U.S. gpm</i>	$\frac{\text{rpm} \times (\text{in}^3/\text{rev}) \times \text{volumetric eff.}}{231}$
<i>Fluid motor speed</i>	<i>rpm</i>	$\frac{231 \times \text{flow rate}(\text{U.S. gpm}) \times \text{volumetric eff.}}{\text{displacement} (\text{in}^3/\text{rev})}$
<i>Fluid motor torque</i>	<i>lbs. in.</i>	$\frac{\text{pressure}(\text{psi}) \times \text{displacement} (\text{in}^3/\text{rev}) \times \text{mech. eff.}}{2p}$
<i>Fluid motor power</i>	<i>hp</i>	$\frac{\text{rpm} \times (\text{in}^3/\text{rev}) \times (\text{psi}) \times \text{overall eff.}}{395934}$
<b>(metric)</b>		
<i>Pump input torque</i>	<i>Nm</i>	$\frac{\text{pressure}(\text{bar}) \times \text{displacement} (\text{cm}^3/\text{rev})}{20p \times \text{mech. eff.}}$
<i>Pump input power</i>	<i>kW</i>	$\frac{\text{rpm} \times (\text{cm}^3/\text{rev}) \times (\text{bar})}{600000 \times \text{overall eff.}}$
<i>Pump output flow</i>	<i>Lpm</i>	$\frac{\text{rpm} \times (\text{cm}^3/\text{rev}) \times \text{volumetric eff.}}{1000}$
<i>Fluid motor speed</i>	<i>rpm(min<sup>-1</sup>) (tr/mn)</i>	$\frac{1000 \times \text{flow rate} (\text{Lpm}) \times \text{volumetric eff.}}{\text{displacement} (\text{cm}^3/\text{rev})}$
<i>Fluid motor torque</i>	<i>Nm</i>	$\frac{\text{pressure}(\text{bar}) \times \text{displacement} (\text{cm}^3/\text{rev}) \times \text{mech. eff.}}{20p}$
<i>Fluid motor power</i>	<i>kW</i>	$\frac{\text{rpm} \times (\text{cm}^3/\text{rev}) \times (\text{bar}) \times \text{overall eff.}}{600000}$



**Denison Hydraulics Inc**

14249 Industrial Parkway  
 Marysville, OH 43040 USA  
 Tel : ..... 937-644-3915  
 Fax : ..... 937-642-3738  
 E-mail:  
[denison@denisonhydraulics.com](mailto:denison@denisonhydraulics.com)

*Call toll-free*  
**800-551-5956**  
*in North America or*  
*visit*  
[www.denisonhydraulics.com](http://www.denisonhydraulics.com)  
*to locate a*  
**Denison representative**  
*nearest you.*

**North America**

**Canada**

Denison Hydraulics Canada Inc.  
 2880 Brighton Road, Unit 1  
 Oakville, ON L6H 5S3, Canada  
 Tel : +1 (905) 829-5800  
 Fax : +1 (905) 829-5805

**Latin America**

**Mexico, Central America, South America, Caribbean countries**

Denison Hydraulics Inc.  
 7850 NW 146 Street  
 Suite 512  
 Miami Lakes, FL 33016, USA  
 Tel : +1 (305) 362-2246  
 Fax : +1 (305) 362-6220

**Asia-Pacific**

**Australia**

Denison Hydraulics PTY  
 41-43 St Hilliers Road  
 P.O.Box 192  
 Auburn N.S.W. 2144, Australia  
 Tel : +61 (2) 9646 5200  
 Fax : +61 (2) 9643 1305

**Hong Kong**

Denison Hydraulics Ltd.  
 Unit 6A, 33/F Cable TV Tower  
 9 Hoi Shing Road, Tsuen Wan  
 NT, Hong Kong  
 Tel : +852 2498 8381  
 Fax : +852 2499 1522

**Japan**

Denison Japan Inc.  
 4-2-1 Tsujido-Shinmachi  
 Fujisawa 251-0042, Japan  
 Tel : +81 (466) 35-3050  
 Fax : +81 (466) 35-2019

**People Republic of China**

Shanghai Denison Hydraulics  
 Engineering Ltd.  
 Room 8018, No. 601  
 Zhang Yang Road,  
 Pudong New Area  
 Shanghai 200120, P.R. China  
 Tel : +86 (21) 58205042 / 34  
 Fax : +86 (21) 58205014

**Singapore**

Denison Hydraulics PTE LTD  
 Blk 4012 Ang Mo Kio Ave 10,  
 Unit #07-01D Techplace I  
 Singapore 569628  
 Tel : +65 268 7840  
 Fax : +65 268 7847

**Taiwan**

Denison Hydraulics LTD  
 6F-10, No. 79,  
 Sec. 2 Roosevelt Rd,  
 Taipei, Taiwan, ROC  
 Tel : +886-2-23645101  
 Fax : +886-2-23639025

**Europe**

**Austria**

Denison Hydraulics GmbH  
 Zweigniederlassung Linz  
 Haibachstraße 69  
 4061 Pasching, Austria  
 Tel : +43 (72 29) 48 87  
 Fax : +43 (72 29) 6 30 92

**Benelux**

Denison Hydraulics Benelux B.V.  
 Pascalstraat 100  
 3316 GR Dordrecht, Holland  
 Tel : +31 (78) 6543 070  
 Fax : +31 (78) 6175 755

**Denmark**

Denison Hydraulics Denmark A/S  
 Industrikrogen 2  
 2635 Ishøj, Denmark  
 Tel : +45 (4371) 15 00  
 Fax : +45 (4371) 15 16

**Finland**

Denison Lokomec Oy  
 Polunmäenkatu 22  
 P.O. Box 116  
 33721 Tampere, Finland  
 Tel : + 358 (3) 357 5100  
 Fax : + 358 (3) 357 5111

**France**

Denison Hydraulics S.A.  
 14 route du bois blanc  
 BP 539  
 18105 Vierzon, France  
 Tel : +33 (2) 48 53 01 20  
 Fax : +33 (2) 48 75 02 91

**Great Britain**

Denison Hydraulics UK LTD  
 Kenmore Road  
 Wakefield 41, Industrial Park  
 Wakefield, WF2 0XE  
 West Yorkshire, England  
 Tel : +44 (1924) 826 021  
 Fax : +44 (1924) 826 146

**Germany**

Denison Hydraulics GmbH  
 Auf dem Sand 14  
 D 40721 Hilden, Germany  
 Tel : +49 (0) 2103 / 940-3  
 Fax : +49 (0) 2103 / 940-558

**Italy**

Denison Hydraulics Srl  
 Via Le Europa 68  
 20090 Cusago (MI), Italy  
 Tel : +39 (02) 90330-1  
 Fax : +39 (02) 90390694/5/6

Denison Calzoni S.p.A  
 Via Caduti di Sabbiano15/17  
 40011 Anzola dell'Emilia  
 Bologna, Italy  
 Tel : +39 (051) 6501611  
 Fax : +39 (051) 736221

**Spain**

Denison Hydraulics S.A.  
 Gomis 1  
 08023 Barcelona, Spain  
 Tel : +34 (93) 253 1990  
 Fax : +34 (93) 211 6507

**Sweden**

Denison Hydraulics Svenska AB  
 Sporregatan 13  
 213 77 - Malmö, Sweden  
 Tel : +46 (40) 600 13 00  
 Fax : +46 (40) 600 13 50

**Others**

**Other European, Middle East, African countries**

Denison Hydraulics S.A.  
 ATTN: Export Office  
 14 route du bois blanc  
 BP 538  
 18105 Vierzon, France  
 Tel : +33 (2) 48 53 01 20  
 Fax : +33 (2) 48 53 01 46

For more information, please contact:

**DENISON Hydraulics**

<http://www.denisonhydraulics.com>